



EB2



Some Optional Equipment Shown.

The Eagle EB2 is a versatile towing and recovery unit. Its patented claw system provides you with a self loading wheel lift without unnecessary additional hydraulic components that increase maintenance and down time. Hook ups can be achieved in seconds. And since the Eagle claw works from the inside of the tire, curb side hook ups can be achieved even when there is no clearance between the tire and curb. The EB2 with its 8,000 lb. hydraulic winch and cross bar sheave attachment will allow you to handle a variety of recovery situations. For more information on the EB2 contact your local Eagle distributor.

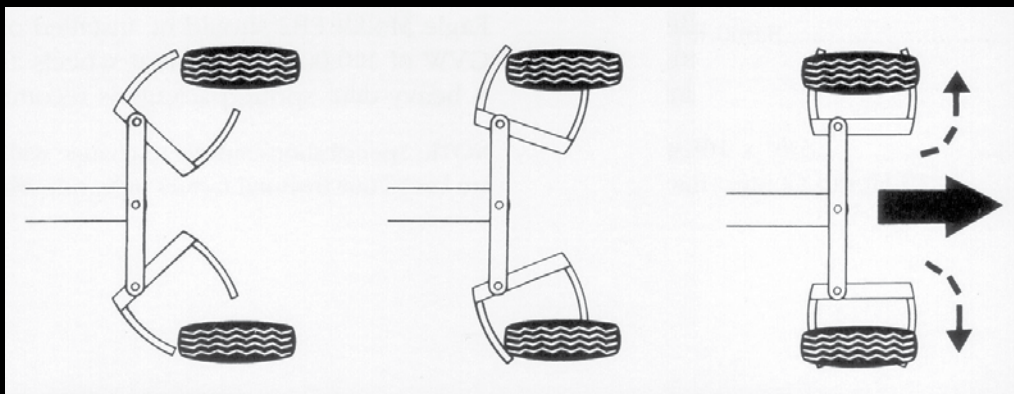



BOOM SPECIFICATIONS

At Boom End Swivel	16,000 lbs.
Using Crossbar Sheave Attachment	
Retracted	4,000 lbs.
Extended	3,000 lbs.
Maximum Angle	34°
Maximum Hook Height	80 1/2"
Maximum Reach past Tailboard at 30°	61 1/2"

STANDARD FEATURES

- Adjustable Width Steel Modular Body, 60" C.A.
- Hydraulic Powered Boom (Elevation & Extension)
- Eagle Claw Self Loading Wheel Lift
- Left & Right Side Tool Compartment
- Removable Tire Adapters
- 8,000 lb. Hydraulic Winch
- 100' x 3/8" Cable
- Cable Tensioner
- Safety Chains & Mud Flaps
- Crossbar Sheave Attachment
- Federal Standard 108 Lighting
- Dual Rear Controls
- In-Cab Remote Control
- 1 Pair of Shallow Frame Forks
- Tailboard Mounted "D" Rings
- Two Way Sheave Wheel
- 1 Pair of Safety Straps
- Clutch Pump

WINCH RATING & CABLE

Rating (first layer of drum)	8,000 lbs.
Diameter and Length (each winch)	3/8" x 100'
Type	6 x 19 IPS



UNDERLIFT SPECIFICATIONS

Fully Retracted	3,500 lbs.
Fully Extended	3,000 lbs.
Underlift Reach to End of Crossbar	
On the Ground	60"
At Normal Tow Position	64 1/2"
Tow Rating	7,500 lbs.

EB2

CHASSIS RECOMMENDATION

Minimum GVWR	10,000 lbs.
Minimum Cab to Axle (Clear)	60"
Maximum Cab to Axle (Clear)	84"
Maximum Frame Height	38"

OPTIONAL FEATURES

- Composite Modular Body
- Light Pylon
- Aluminum Tubular Light Pylon
- Fold Down Light Bar Bracket
- Deep Frame Lift Forks
- Aluminum Modular Body
- 24" Tunnel Tool Box
- Additional Work Lights
- Claw Extenders (Set of 4)
- Sling Strap Attachment



All ratings are based on structural factors only, not vehicle capacities or capabilities. Specifications shown are approximations and may vary depending on chassis selected. Miller Industries Towing Equipment Inc. reserves the right to change or modify product and/or specifications without notice or obligation. Some equipment shown is optional.



DISTRIBUTED BY:

8503 Hilltop Drive • Ooltewah, TN 37363
 800-292-0330 • 423-238-4171
 FAX 423-238-5371 • MILLERIND.com