

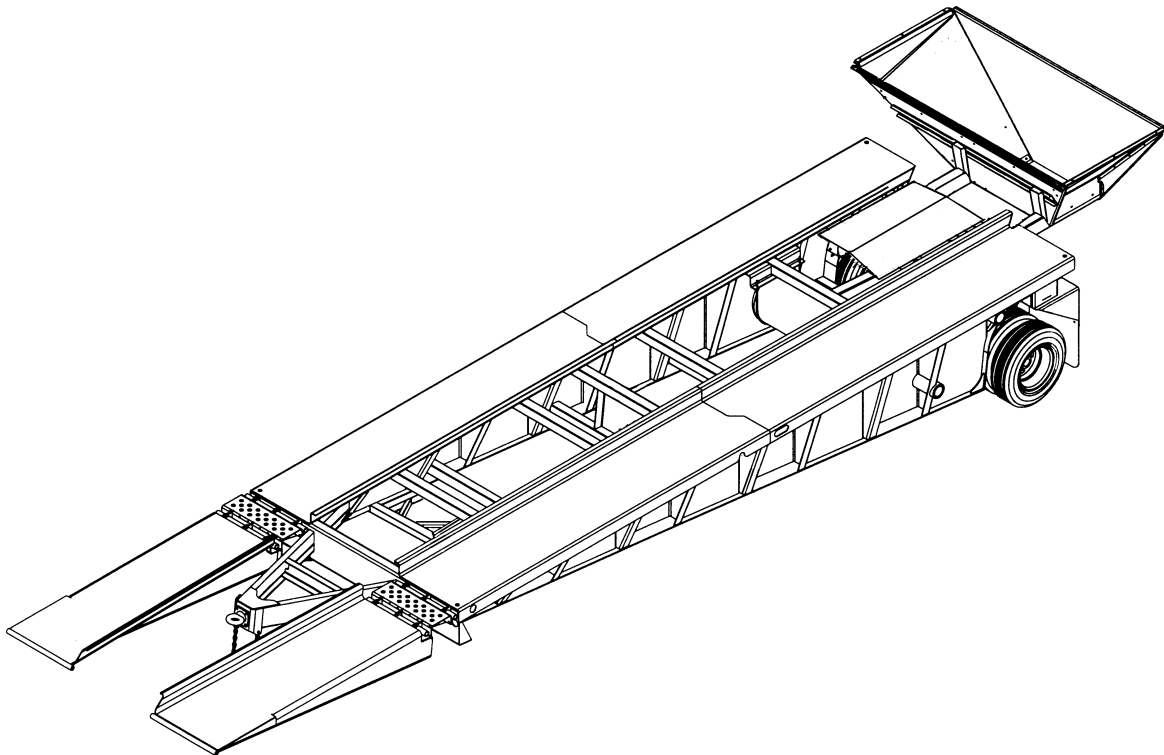

**MODEL 124
RAMP TRAILER
OPERATOR'S MANUAL**



**1900 NORTH STREET
MARYSVILLE, KANSAS 66508
(785) 562-5381**

WARRANTY

MANUFACTURER'S GUARANTEE POLICY

LANDOLL CORPORATION WARRANTY

LANDOLL warrants each new and unused LANDOLL machine, when properly assembled, adjusted, and operated, to be free of defects in material and workmanship, in normal use and when properly serviced, for a period of twelve (12) months after date of delivery by the Dealer to the original retail purchaser. LANDOLL shall repair or replace, at its option, freight on board (f.o.b.) at its factory or designated DEALER location, any part or parts of such new and unused machine which shall have been reported in writing to LANDOLL within thirty (30) days from date of failure thereof and which LANDOLL inspection shall disclose to have been defective. Defective parts must be returned to the LANDOLL factory, freight prepaid. LANDOLL will not be liable for labor, transportation, or any other charges resulting from replacement of a defective part. This warranty is void if any part not supplied by LANDOLL is used in assembly or repair, or if the machine has been altered, abused, or neglected. LANDOLL repair parts are warranted for ninety (90) days from date of replacement or for the unexpired warranty period of the applicable LANDOLL machine, whichever period is longer. LANDOLL makes no warranty, whatsoever, as to purchased component parts and other trade accessories, except to the extent that such items are warranted by the manufacturer thereof. **THIS WARRANTY IS EXCLUSIVE AND IN LIEU OF ALL OTHER WARRANTIES, WHETHER EXPRESSED, IMPLIED, OR STATUTORY (INCLUDING WARRANTIES OF MERCHANTABILITY AND FITNESS FOR PURPOSE), AND LANDOLL SHALL NOT BE LIABLE FOR SPECIAL OR CONSEQUENTIAL DAMAGES OF ANY KIND ON ACCOUNT OF ANY LANDOLL PRODUCT.**

NO EMPLOYEE OR REPRESENTATIVE IS AUTHORIZED TO CHANGE THIS WARRANTY, VERBALLY OR IN WRITING, OR GRANT ANY OTHER WARRANTY.

LANDOLL CORPORATION, WHOSE POLICY IS ONE OF CONTINUOUS IMPROVEMENT, RESERVES THE RIGHT TO MAKE CHANGES WITHOUT OBLIGATION TO MODIFY PREVIOUSLY PRODUCED EQUIPMENT.





**MODEL 124
RAMP TRAILER
OPERATOR'S MANUAL**

PURCHASED FROM: _____ **DATE** ____ / ____ / ____

ADDRESS: _____

PHONE NO.: _____ **SERIAL NO.:** _____

REPORTING SAFETY DEFECTS

If you believe that your vehicle has a defect which could cause a crash or could cause injury or death, you should immediately inform the National Highway Traffic Safety Administration (NHTSA) in addition to notifying Landoll Manufacturing.

If NHTSA receives similar complaints, it may open an investigation, and if it finds that a safety defect exists in a group of vehicles, it may order a recall and remedy campaign. However, NHTSA cannot become involved in individual problems between you, your dealer, or Landoll Manufacturing.

To contact NHTSA, you may either call the Auto Safety Hotline toll-free at 1-800-424-9393 (or 366-0123 in Washington, D.C. area) or write to: NHTSA, U.S. Department of Transportation, Washington, D.C. 20590. You can also obtain other information about motor vehicle safety from the Hotline.

In the event of a defect or problem with your LANDOLL equipment, please notify LANDOLL CORPORATION:

**LANDOLL CORPORATION
SALES AND SERVICE
1900 NORTH STREET
MARYSVILLE, KANSAS 66508**

OR PHONE:

**(785) 562-5381
1-800-HAULLOLL
(1-800-428-5655)
FAX NO.: (785) 562-4893**

TABLE OF CONTENTS

SECTION	DESCRIPTION	PAGE NO.
1	INTRODUCTION	
2	STANDARD SPECIFICATIONS	
3	OPERATING INSTRUCTIONS	
3-1	GENERAL	3-1
3-2	PRE-COUPLING OF TRAILER AND TRUCK	3-1
3-3	COUPLING OF THE TOWING VEHICLE TO THE TRAILER	3-3
3-4	CONNECTING TOWING VEHICLE SERVICES TO THE TRAILER	3-3
3-5	RAISING REAR OF TRAILER TO TRANSPORT POSITION	3-3
3-6	TOWING VEHICLE AND TRAILER HOOK-UP AND CHECK-OUT	3-4
3-7	TOWING THE TRAILER	3-4
3-8	PARKING THE TRAILER	3-5
3-9	UNCOUPLING TOWING VEHICLE FROM TRAILER	3-5
3-10	LOWERING TRAILER TO RAMP POSITION	3-5
3-11	OPERATING FRONT RAMPS	3-6
3-12	OPERATING HOPPER	3-7
3-13	EMERGENCY BRAKE RELEASE	3-7
3-14	AIR RIDE OPERATION	3-9
3-15	REAR IMPACT GUARD SYSTEM	3-9
3-16	COLD WEATHER OPERATION	3-10
3-17	HOT WEATHER OPERATION	3-10
4	MAINTENANCE AND LUBRICATION	
4-1	GENERAL	4-1
4-2	MAINTENANCE SCHEDULE	4-1
4-3	MAINTENANCE PROCEDURES	4-2
4-4	FRAME AND DECKS	4-2
4-5	ELECTRICAL SYSTEM	4-3
4-6	BRAKE SYSTEM MAINTENANCE	4-3
4-7	HUB AND DRUM MAINTENANCE	4-9
4-8	WHEEL BEARING LUBRICATION AND ADJUSTMENT	4-11
4-9	SUSPENSION MAINTENANCE	4-11
4-10	ALIGNMENT	4-13
4-11	TIRES	4-15
4-12	WHEELS	4-16
5	TROUBLESHOOTING	

SAFETY PRECAUTIONS



THIS IS THE SAFETY ALERT SYMBOL. IT IS USED TO ALERT YOU TO POTENTIAL INJURY HAZARDS. OBEY ALL SAFETY MESSAGES THAT FOLLOW THIS SYMBOL TO AVOID POSSIBLE INJURY OR DEATH.

DANGER

DANGER INDICATES AN IMMEDIATELY HAZARDOUS SITUATION WHICH, IF NOT AVOIDED, WILL RESULT IN DEATH OR SERIOUS INJURY.

WARNING

WARNING INDICATES A POTENTIALLY HAZARDOUS SITUATION WHICH, IF NOT AVOIDED, COULD RESULT IN DEATH OR SERIOUS INJURY.

CAUTION

CAUTION INDICATES A POTENTIALLY HAZARDOUS SITUATION WHICH, IF NOT AVOIDED, MAY RESULT IN MINOR OR MODERATE INJURY.

CAUTION

CAUTION USED WITHOUT THE SAFETY ALERT SYMBOL INDICATES A POTENTIALLY HAZARDOUS SITUATION WHICH, IF NOT AVOIDED, MAY RESULT IN PROPERTY DAMAGE.



This manual provides operating, servicing, and maintenance instructions, for Model 124 Ramp Trailers, manufactured by Landoll Corporation, Marysville, Kansas 66508.

- SECTION 1** gives basic instructions on the use of this manual.
- SECTION 2** gives specifications for the trailer, including measurements and component specifications. A Standard Bolt Torque Table is provided to give guidelines for bolt torques to be used when servicing this product.
- SECTION 3** gives instructions for the proper operation of the equipment.
- SECTION 4** gives general maintenance procedures, a maintenance schedule, and a lubrication schedule. Improper maintenance will void your warranty.

IF YOU HAVE ANY QUESTIONS CONTACT:

**LANDOLL CORPORATION
1900 NORTH STREET
MARYSVILLE, KANSAS 66508
or phone:
(785) 562-5381 or
(800) 428-5655
or FAX:
(785) 562-4893**

- SECTION 5** is a troubleshooting guide to aid in diagnosing and solving problems with the trailer.
- PARTS LIST** is a separate manual showing the various assemblies, subassemblies, and systems. Refer to that manual when ordering Landoll replacement parts. Order parts from your Landoll dealer.
- WARRANTY** The Warranty Registration form is located with the product documents. Fill it out and mail it within 15 days of purchase. The Warranty is printed inside the front cover.

NOTE: IMPROPER ASSEMBLY, MODIFICATION, OR MAINTENANCE OF YOUR LANDOLL EQUIPMENT CAN VOID YOUR WARRANTY.

- COMMENTS** Address comments or questions regarding this publication to:

**LANDOLL CORPORATION
1900 NORTH STREET
MARYSVILLE, KANSAS 66508
ATTENTION: PUBLISHING -DEPT. 55**

STANDARD SPECIFICATIONS

OVERALL LENGTH:
 RAMP FOLDED UP 33'-5"
 RAMP FOLDED DOWN 35'-1"

OVERALL WIDTH: 8'-6"

GVWR: 11,400 LBS.

LOAD ANGLE: 6.5°

JACK AIR OPERATED

HITCH: HEAVY DUTY PINTLE EYE W/ SAFETY CHAINS

HOPPER: FULL WIDTH TELESCOPING ADJUSTABLE W/ RUBBER SKIRT BOTTOM
 VERTICAL ADJUST: 25° - AIR SPRING
 HORIZONTAL ADJUST: EXTENDS 30" W/ AIR CYLINDER

ELECTRICAL HOOKUP: 7-WAY CONNECTOR

AIR HOOKUP GLAD HANDS

NOTE: FOR GENERAL TORQUE SPECIFICATIONS, REFER TO TABLE 2-2.

FASTENER SPECIFICATIONS AND TORQUES (FOR 9K-15K AXLES)				
DESCRIPTION	APPLICATION	PART NO.	MIN. TORQUE	MAX. TORQUE
SPINDLE NUT INNER OUTER	9K-15K 9K-15K	SEE SPINDLE TORQUE/BEARING ADJUSTMENT PAGE 2-4.		
GREASE ZERK	CAM BUSHING SPIDER		5 8	15 8
CAM BRACKETS			3	4
AIR CHAMBER	12K-15K AIR BRAKE		50	55
5/8-11 HEX LOCK NUT	9K, 10K U-BOLT	006-038-00	110	130
5/8-11 SOCKET HEAD CAP SCREW	DRUM MTG	007-161-00	160	180
5/8-18 HEX CAP SCREW	DRUM MTG	007-165-00	160	180
PLASTIC OIL CAP	OIL HUBS	021- 033,24,35,36	20	30

Table 2-1 Fastener Specifications and Torques

LANDOLL CORPORATION GENERAL TORQUE SPECIFICATIONS (REV. 4/97)

THIS CHART PROVIDES TIGHTENING TORQUES FOR GENERAL PURPOSE APPLICATIONS WHEN SPECIAL TORQUES ARE NOT SPECIFIED ON PROCESS OR DRAWING.

ASSEMBLY TORQUES APPLY TO PLATED NUTS AND CAPSCREWS ASSEMBLED WITHOUT SUPPLEMENTAL LUBRICATION (AS RECEIVED CONDITION). THEY DO NOT APPLY IF SPECIAL GRAPHITE MOLY-DISULFIDE OR OTHER EXTREME PRESSURE LUBRICANTS ARE USED.

WHEN FASTENERS ARE DRY (SOLVENT CLEANED), ADD 33% TO AS RECEIVED CONDITION TORQUE.

BOLT HEAD IDENTIFICATION MARKS INDICATE GRADE AND MAY VARY FROM MANUFACTURER TO MANUFACTURER.

THICK NUTS MUST BE USED ON GRADE 8 CAPSCREWS.

USE VALUE IN [] IF USING PREVAILING TORQUE NUTS.

TORQUE IS SPECIFIED IN FOOT POUNDS

UNC Size	SAE Grade 2	SAE Grade 5	SAE Grade 8	UNF Size	SAE Grade 2	SAE Grade 5	SAE Grade 8
1/4-20	4 [5]	6 [7]	9 [11]	1/4-28	5 [6]	7 [9]	10 [12]
5/16-18	8 [10]	13 [16]	18 [22]	5/16-24	9 [11]	14 [17]	20 [25]
3/8-16	15 [19]	23 [29]	35 [43]	3/8-24	17 [21]	25 [31]	35 [44]
7/16-14	24 [30]	35 [43]	55 [62]	7/16-20	27 [34]	40 [50]	60 [75]
1/2-13	35 [43]	55 [62]	80 [100]	1/2-20	40 [50]	65 [81]	90 [112]
9/16-12	55 [62]	80 [100]	110 [137]	9/16-18	60 [75]	90 [112]	130 [162]
5/8-11	75 [94]	110 [137]	170 [212]	5/8-18	85 [106]	130 [162]	180 [225]
3/4-10	130 [162]	200 [250]	280 [350]	3/4-16	150 [188]	220 [275]	320 [400]
7/8-9	125 [156]	320 [400]	460 [575]	7/8-14	140 [175]	360 [450]	500 [625]
1-8	190 [237]	408 [506]	680 [850]	1-14	210 [263]	540 [675]	760 [950]
1-1/8-7	270 [337]	600 [750]	960 [1200]	1-1/8-12	300 [375]	660 [825]	1080 [1350]
1-1/4-7	380 [475]	840 [1050]	1426 [1782]	1-1/4-12	420 [525]	920 [1150]	1500 [1875]
1-3/8-6	490 [612]	110 [1375]	1780 [2225]	1-3/8-12	560 [700]	1260 [1575]	2010 [2512]
1/1-2-6	650 [812]	1460 [1825]	2360 [2950]	1/1-2-12	730 [912]	1640 [2050]	2660 [3325]

METRIC

COARSE THREAD METRIC CLASS 10.9 FASTENERS AND CLASS 10.0 NUTS AND THROUGH HARDENED FLAT WASHERS, PHOSPHATE COATED, ROCKWELL "C" 38-45.

USE VALUE IN [] IF USING PREVAILING TORQUE NUTS.

Nominal Thread Diameter mm	Standard Torque		Nominal Thread Diameter mm	Standard Torque	
	Newton-Meters	Foot-Pounds		Newton-Meters	Foot-Pounds
6	10 [14]	7 [10]	20	385 [450]	290 [335]
7	16 [22]	12 [16]	24	670 [775]	500 [625]
8	23 [32]	17 [24]	27	980 [1105]	730 [825]
10	46 [60]	34 [47]	30	1330 [1470]	990 [1090]
12	80 [101]	60 [75]	33	1790 [1950]	1340 [1450]
14	125 [155]	90 [115]	36	2325 [2515]	1730 [1870]
16	200 [240]	150 [180]	39	3010 [3210]	2240 [2380]
18	275 [330]	205 [245]			

Table 2-2 General Torque Specifications

**LANDOLL CORPORATION
HYDRAULIC FITTING TORQUE SPECIFICATIONS
37° JIC, ORS, & ORB (REV. 10/97)**

THIS CHART PROVIDES TIGHTENING TORQUES FOR HYDRAULIC FITTING APPLICATIONS WHEN SPECIAL TORQUES ARE NOT SPECIFIED ON PROCESS OR DRAWING.

ASSEMBLY TORQUES APPLY TO PLATED CARBON STEEL AND STAINLESS STEEL FITTINGS ASSEMBLED WITHOUT SUPPLEMENTAL LUBRICATION (AS RECEIVED CONDITION). THEY DO NOT APPLY IF SPECIAL GRAPHITE MOLY-DISULFIDE OR OTHER EXTREME PRESSURE LUBRICANTS ARE USED.

BRASS FITTINGS AND ADAPTERS - 65% OF THE TORQUE VALUE FOR STEEL. STAINLESS STEEL, ALUMINUM AND MONEL - THREADS ARE TO BE LUBRICATED.

TORQUE IS SPECIFIED IN FOOT POUNDS

PARKER BRAND FITTINGS

Dash Size	37 Degree JIC	O-Ring (ORS)	O-Ring Boss (ORB)
-4	11-13	15-17	13-15
-5	14-16	—	21-23
-6	20-22	34-36	25-29
-8	43-47	58-62	40-44
-10	55-65	100-110	57.5-62.5
-12	80-90	134-146	75-85
-16	115-125	202-218	109-121
-20	160-180	248-272	213-237
-24	185-215	303-327	238-262
-32	250-290	—	310-340

**LANDOLL CORPORATION
HYDRAULIC FITTING TORQUE SPECIFICATIONS
37° JIC, ORS & ORB (REV. 10/97)**

THIS CHART PROVIDES TIGHTENING TORQUES FOR HYDRAULIC FITTING APPLICATIONS WHEN SPECIAL TORQUES ARE NOT SPECIFIED ON PROCESS OR DRAWING.

ASSEMBLY TORQUES APPLY TO PLATED CARBON STEEL AND STAINLESS STEEL FITTINGS ASSEMBLED WITHOUT SUPPLEMENTAL LUBRICATION (AS RECEIVED CONDITION). THEY DO NOT APPLY IF SPECIAL GRAPHITE MOLY-DISULFIDE OR OTHER EXTREME PRESSURE LUBRICANTS ARE USED.

BRASS FITTINGS AND ADAPTERS - 65% OF THE TORQUE VALUE FOR STEEL.

TORQUE IS SPECIFIED IN FOOT POUNDS.

AEROQUIP BRAND FITTINGS

Dash Size	37 Degree JIC	O-Ring (ORS)	O-Ring Boss (ORB)
-4	11-12	10-12	14-16
-5	15-16	—	18-20
-6	18-20	18-20	24-26
-8	38-42	32-35	50-60
-10	57-62	46-50	72-80
-12	79-87	65-70	125-135
-14	—	—	160-180
-16	108-113	92-100	200-220
-20	127-133	125-140	210-280
-24	158-167	150-165	270-360
-32	245-258	—	—

Table 2-3 Hydraulic Fitting Torque Specifications

SPECIFIC BOLT TORQUES

WHEEL AND RIM TORQUE REQUIREMENTS				
DESCRIPTION	APPLICATION	PART NO.	TORQUE MIN. FT.-LBS.	TORQUE MAX FT.-LBS.
5/8-18 90° CONE NUT	FLAT DISC WHEEL	006-081-00	175	225
5/8-18 90° CONE NUT	CLAMP RING 033-052-01	006-109-00	190	210 GREASED THREADS
3/4-10 HEX NUT	DEMOUNTABLE RIM CLAMP	006-117-00	210	260
3/4-16 SPHERICAL NUT	SINGLE WHEEL INNER DUAL	006-064-01,02 006-069-01, 02	450 450	500 500
1-1/8 -16 SPHERICAL NUT	OUTER DUAL	006-070-01, 02	450	500
5/8-18 FLANGE NUT	WHEELS	006-058-00	275	325

SPINDLE TORQUE/BEARING ADJUSTMENT (FOR 9K-15K AXLES)

1. Install the bearing and washer into the hub. Thread on the inner nut, rotate the hub and tighten the nut until the hub will not rotate. This requires a minimum of 100 ft.-lb. of torque.
2. Loosen the nut to remove preload torque.
3. Hand tighten the nut and back it off 1/4 to 3/8 turn.
4. Place the tang washer on the spindle and bend one tang inward over the nut. This will keep the inner nut from turning while torque is applied to the outer nut.
5. Install the outer nut and torque it to 225-250 ft.-lb. Insure that the inner nut does not turn. Bend two tangs from the tang washer over the outer nut flats to secure.
6. Install cap with the o-ring and plug installed. Rotate the hub and check the bearing adjustment. The allowable end play is .001"-.010".

DANGER

FAILURE TO BACK OFF THE INNER ADJUSTING NUT COULD CAUSE BEARING AND AXLE SPINDLE OVERHEATING OR DAMAGE, WHICH COULD RESULT IN THE WHEEL LOCKING UP OR COMING OFF DURING VEHICLE OPERATION.

3-1 GENERAL

This section supplies information for operation of the trailer. It describes and locates controls, and gives general operation procedures. Read all instructions, warnings, cautions, and danger notes before attempting to operate the trailer. Operators must have proper training before operating the trailer. See Figure 3-2 for trailer terminology.

IMPORTANT

THIS TRAILER IS TO BE USED AS A RAMP ONLY AND IS NOT INTENDED TO HAUL ADDITIONAL EQUIPMENT IN THE TRANSPORT POSITION.

 **WARNING**

DO NOT OPERATE THE TRAILER WITH ANY KNOWN FAULT THAT MIGHT ENDANGER THE OCCUPANTS, NEARBY WORKERS, OTHER TRAFFIC, THE LOAD, OR THE EQUIPMENT.

3-2 PRE-COUPLING OF TRAILER AND TRUCK

3-2.1 Slowly back the truck (towing vehicle) up to the front end of the trailer so the hitch of the trailer is centered with the truck. Stop the towing vehicle just inches ahead of the trailer. Set truck parking brake.

3-2.2 Check the trailer hitch height. The hitch should be the same height to slightly higher, than the hitch of the towing vehicle. Raise or lower the front of trailer by using the air operated jack. The jack may be raised or lowered using the valve marked "FRONT" on the control panel until the proper hitch height has been obtained (See Figure 3-2).

3-2.3 Connect the service and emergency air hoses of the towing vehicle to their respective gladhand on the front of the trailer. The towing vehicle's air hose couplings are attached and locked to the appropriate gladhands; **red emergency line** to the gladhand with the "**EMERGENCY**" tag, and the **blue service line** to the gladhand with the "**SERVICE**" tag (See Figure 3-1). Chock the trailer wheels before activating the trailer air supply valve in the towing vehicle. Set the trailer brakes.

3-2.4 Check the air brake operations of the trailer as follows:

a. Apply brakes and inspect brake action on all wheels for prompt application.

b. Release brakes. All brakes should release immediately. Air pressure should discharge quickly from the relay emergency valve.

c. Disconnect the emergency air line from the trailer gladhand. Trailer brakes should promptly set.

d. Reconnect the emergency air line to the trailer and activate the trailer air supply valve. The trailer brakes should set.

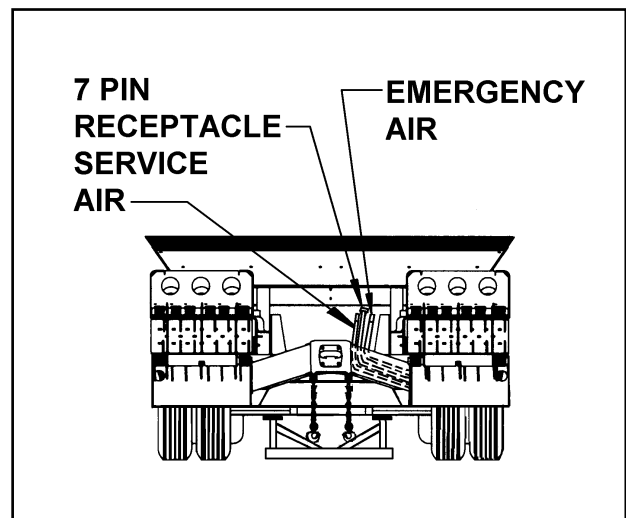

**Figure 3-1 Service Hookups (Front View)
- Air Brakes**

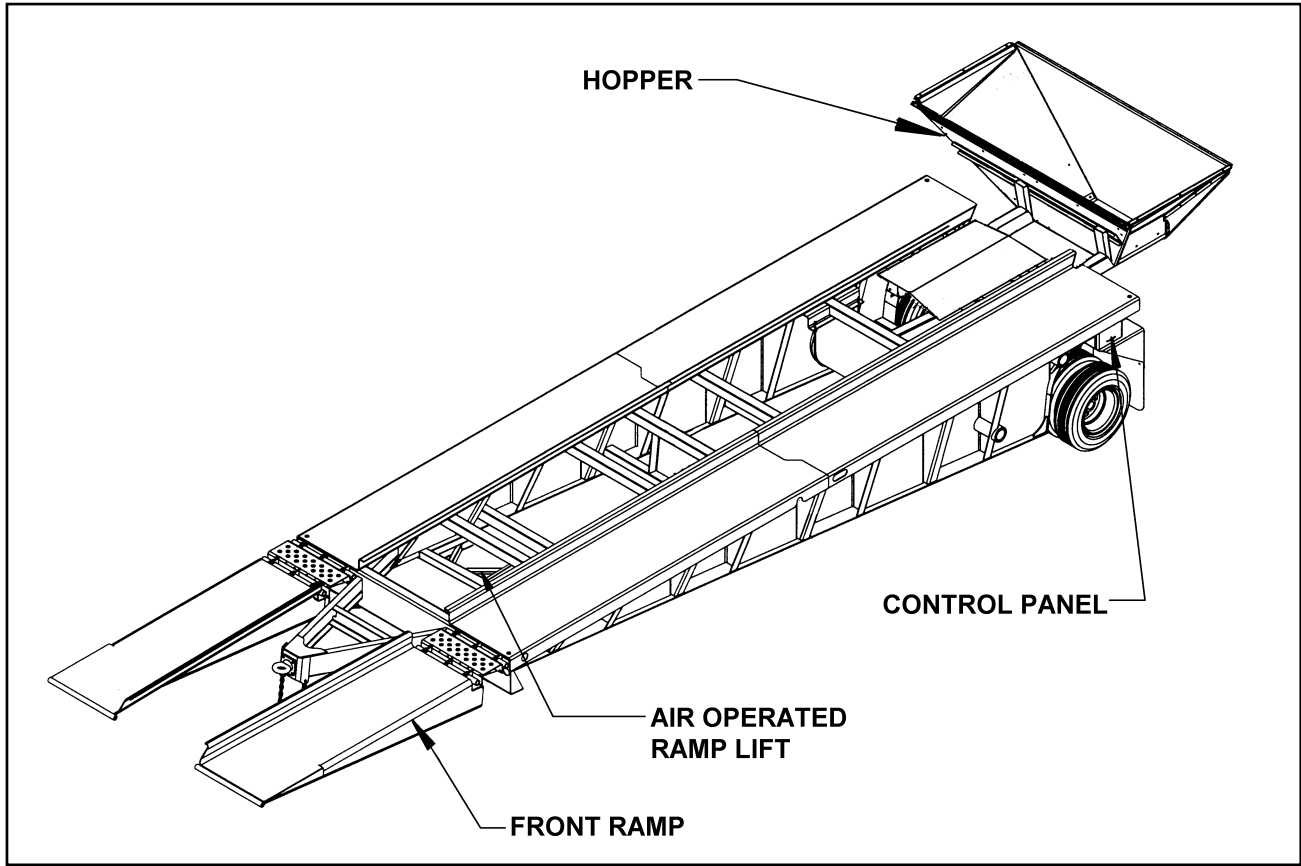

Figure 3-2 Model 124 Trailer Terminology

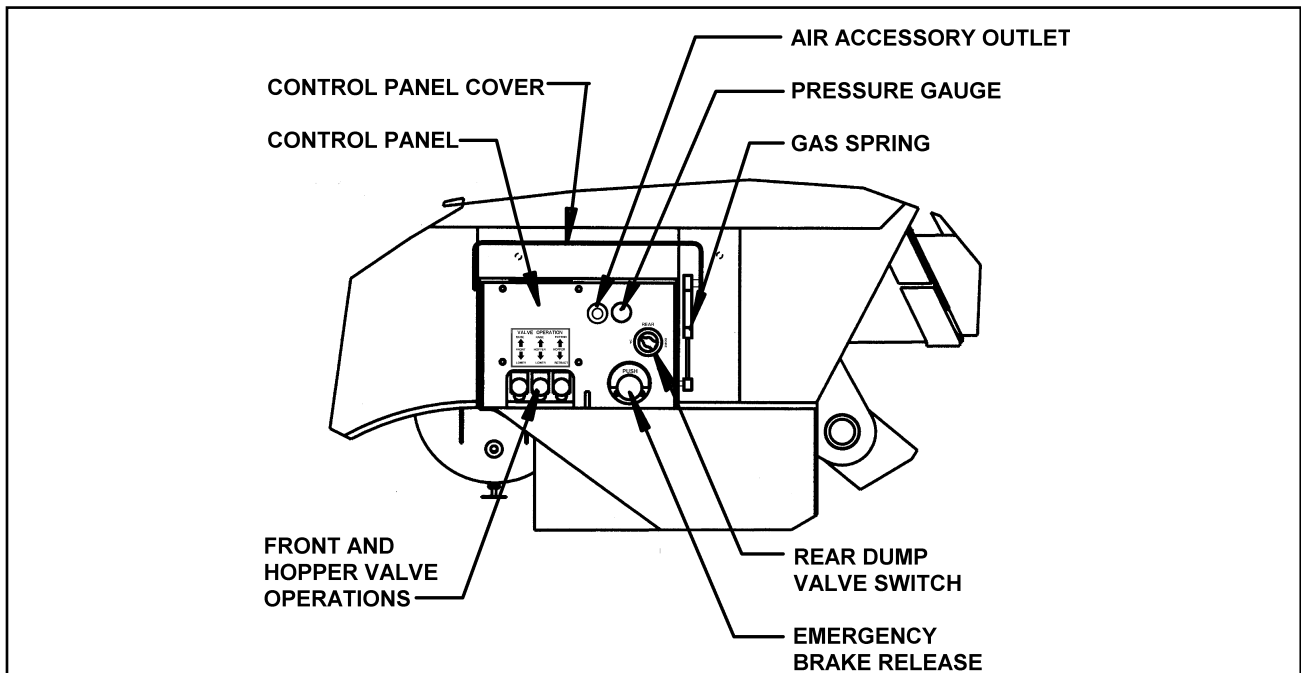

Figure 3-3 Control Panel

3-3 COUPLING OF THE TOWING VEHICLE TO THE TRAILER

 **DANGER**

KEEP ALL PERSONNEL CLEAR OF FRONT, REAR, AND SIDES OF TOWING VEHICLE AND TRAILER DURING COUPLING, COMPONENT OPERATIONS, AND UNCOUPLING. FAILURE TO STAY CLEAR CAN RESULT IN SERIOUS PERSONAL INJURY OR DEATH.

- 3-3.1 Verify the trailer wheels are chocked and brakes function properly.
- 3-3.2 Make sure the towing vehicle's coupler is open.

CAUTION

PUSHING THE TRAILER BACKWARDS CAN DAMAGE LANDING GEAR.

- 3-3.3 Slowly back the towing vehicle so the hitch contacts the trailer hitch. Make sure the hitch is centered and will properly connect up. Set the vehicle brakes.
- 3-3.4 Raise the air operated jack and lock the hitch in place (See Figure 3-2).

IMPORTANT

KEEP BRAKES ENGAGED FOR REMAINDER OF HOOKUP, CHECK-OUT PROCEDURES, AND FOR PARKING.

3-4 CONNECTING TOWING VEHICLE SERVICES TO THE TRAILER

- 3-4.1 Connect the electrical receptacle on the front of the trailer to the towing vehicle (See Figure 3-1).

IMPORTANT

The key on the plug and the keyway in the socket must be properly aligned before inserting the plug into the trailer socket.

3-5 RAISING REAR OF TRAILER TO TRANSPORT POSITION

- 3-5.1 On the control panel at the rear of trailer, locate the switch marked REAR (See Figure 3-3). Turn the switch counterclockwise to the position marked UP. This will inflate the air springs on the suspension and raise the rear of the trailer off the ground. Note that the hinged bumper will also come up. When the trailer has reached the proper ride height, the air springs will automatically stop inflating.

 **CAUTION**

KEEP HANDS AND FEET AWAY FROM TIRES, FRAME, AND BUMPER WHILE TRAILER IS RAISING.

3-6 TOWING VEHICLE AND TRAILER HOOK-UP AND CHECK-OUT



WARNING

FAILURE TO PROPERLY SET AND CHECK PARKING BRAKE, AND CHOCK WHEELS WHEN PARKING AND DURING STORAGE, COULD ALLOW MOVEMENT OF THE TRUCK/TRAILER RESULTING IN SERIOUS PERSONAL INJURY, DEATH, OR DAMAGE TO PROPERTY IN ITS PATH.

- 3-6.1 Assure jack is raised up all the way.
- 3-6.2 Attach safety chains from the trailer to the towing vehicle.
- 3-6.3 Check your maintenance schedule and be sure everything is up-to-date.
- 3-6.4 Set parking brake and carefully remove all wheel chocks. If brakes are not properly set, the truck/trailer may roll when removing wheel chocks.

3-7 TOWING THE TRAILER

- 3-7.1 Driving the towing vehicle with the trailer coupled behind requires constant attention to the overall length of the combination. Turning, passing, acceleration, braking, stopping, and back-up require special attention. When executing steep grades or turning tight curves, the trailer must not be allowed to push the towing vehicle, or jackknifing the trailer with the towing vehicle may result. Application of the trailer brakes to keep the trailer in tow will help prevent this pushing. Braking should begin before descending a hill or attempting a curve, to assure control.
- 3-7.2 Make a moving test of the trailer brakes at low, and medium speeds *before* traveling at highway speed.
- 3-7.3 For trailer with air brakes, monitor the air pressure gauge on the dash of the towing vehicle. Pressure should not fall below the 85 to 95 psi range at any time.

- 3-7.4 The trailer wheels track to the inside of the towing vehicle during turns. Thus, turning corners requires a wide swing to prevent "curb hopping", and to allow the trailer wheels to clear any obstacle on the inside of the corner.
- 3-7.5 To stop, use a gradual and smooth application of brakes. If grabbing occurs, apply less pressure. Grabbing brakes are not efficient.



DANGER

ALWAYS CHECK BEHIND AND UNDER THE TRUCK AND TRAILER FOR PERSONS OR OBJECTS BEFORE MOVING. FAILURE TO CHECK CAN LEAD TO SERIOUS PERSONAL INJURY OR DEATH TO OTHERS, OR DAMAGE TO PROPERTY.

- 3-7.6 Backing should be done with care. Tail overhang, trailer length, and allowable space must be taken into consideration.

3-8 PARKING THE TRAILER

3-8.1 Position truck/trailer on a level, solid surface.

3-8.2 Set the PARKING BRAKE, not the trailer hand brake, and check for proper brake holding.

3-8.3 Chock wheels of trailer.

3-8.4 Check for any air leaks in lines, relay valve, brake air chamber, or any other air system component.

3-9 UNCOUPLING TOWING VEHICLE FROM TRAILER

3-9.1 Park the trailer according to instructions in **Section 3-8**.

3-9.2 Lower the jack to the ground using the valve marked "FRONT" on the control panel.

3-9.3 Disconnect safety chains from the towing vehicle.

3-9.4 Verify that all service lines are disconnected and trailer wheels are chocked.

3-9.5 Unlock hitch and raise trailer hitch by lowering the jack until the hitch is in a position to be disconnected (**See Figure 3-2**).

3-9.6 Disconnect emergency and service air lines.

3-9.7 Pull towing vehicle away from the trailer.

3-10 LOWERING TRAILER TO RAMP POSITION

3-10.1 Lower the front of the trailer to the ground by raising the jack using the valve labeled "FRONT" on the control panel. Continue until the jack is completely retracted, and does not protrude below the bottom of the frame.

3-10.2 Lower the rear of the trailer to the ground by turning the switch marked REAR on the control panel at the rear of the trailer clockwise to the DOWN position. Note that the hinged bumper will rotate downward as the frame lowers (**See Figure 3-3**).



CAUTION

KEEP HANDS AND FEET AWAY FROM TIRES, FRAME, AND BUMPER WHILE FRAME IS LOWERING TO THE GROUND.

3-11 OPERATING FRONT RAMPS

3-11.1 Ramps are double hinged to allow them to flip 180° and are also spring loaded in both directions to allow them to be flipped easier (See Figure 3-2).

! CAUTION

KEEP HANDS AND FEET AWAY FROM RAMP HINGE POINTS WHILE OPERATING.

! CAUTION

1. BEFORE FLIPPING RAMPS, MAKE SURE NO PERSONS OR OBJECTS ARE DIRECTLY IN FRONT OF THE RAMPS.

2. WHEN OPERATING THE RAMPS, DO SO FROM THE SIDE. NEVER STAND IN FRONT OF THE RAMPS WHILE OPERATING.

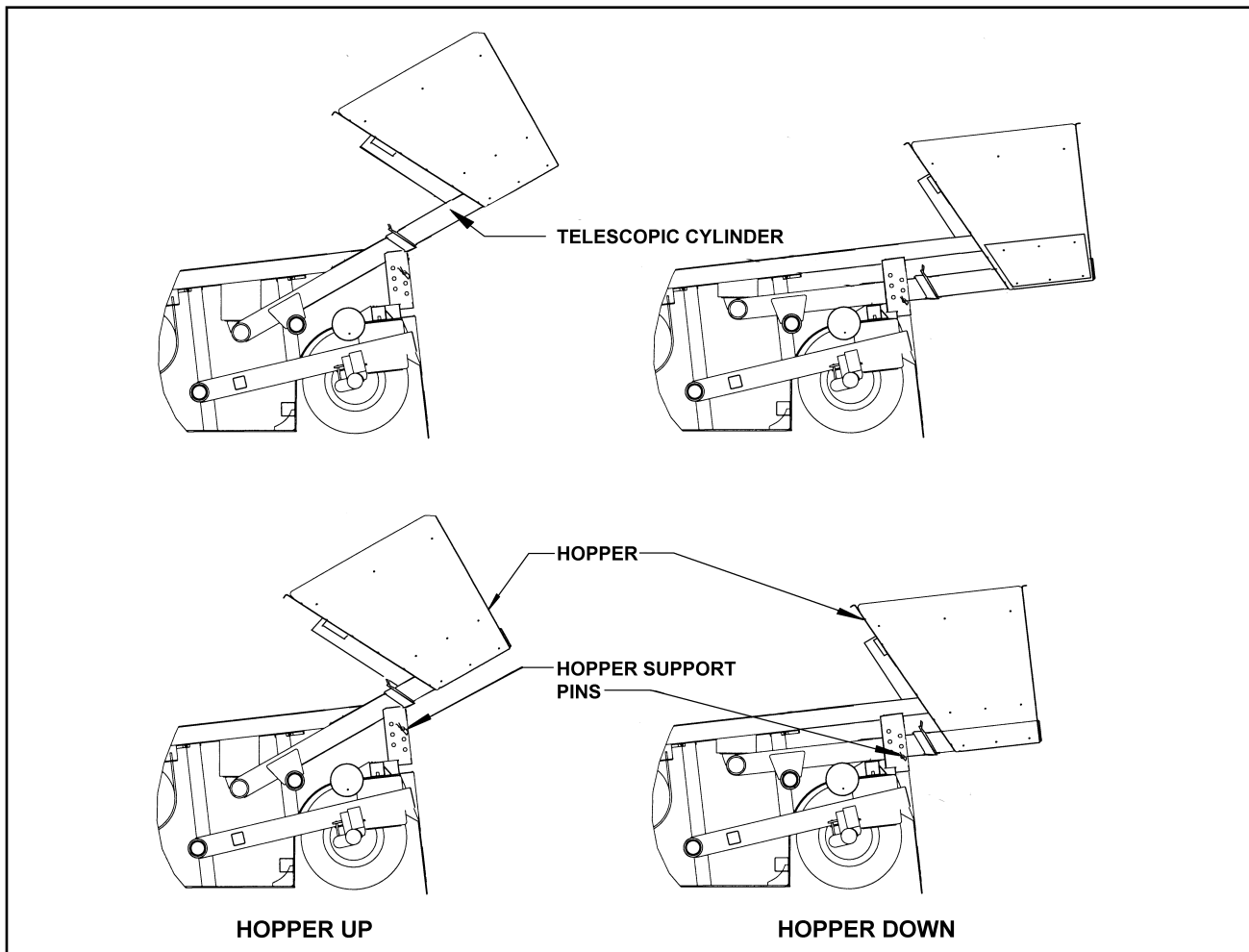

Figure 3-4 Hopper Operation

3-12 OPERATING HOPPER

3-12.1 The height of the hopper at the rear of the trailer may be raised or lowered by operating the valve lever marked HOPPER - RAISE/LOWER on the control panel at the rear of the trailer **(See Figure 3-3)**.

a. To raise the hopper, push the valve lever UP and hold until the desired height is reached.

b. Install the hopper support pins on both sides in the holes directly below the hopper supports **(See Figure 3-4)**.

c. Lower the hopper by pushing DOWN on the valve handle until the hopper is resting on the support pins. It is important to use the hopper support pins to stabilize the hopper and to avoid putting any unnecessary stress on the hopper or hopper air springs **(See Figure 3-4)**.

3-12.2 The hopper can also be extended up to 30" from the rear of the trailer by operating the valve lever marked HOPPER - EXTEND/RETRACT on the control panel at the rear of the trailer **(See Figure 3-3)**.

a. To extend the hopper out from the rear of the trailer, push the valve UP and hold until the desired distance is reached.

b. To retract the hopper back toward the rear of the trailer, push the valve DOWN and hold until the desired distance is reached.



CAUTION

1. KEEP HANDS AND FEET AWAY FROM THE HOPPER WHILE IT IS MOVING.

2. NEVER STAND DIRECTLY BENEATH OR BEHIND THE HOPPER.

3-13 EMERGENCY BRAKE RELEASE

3-13.1 The spring brakes may be manually released to allow the trailer to be moved around the jobsite without the aid of a tractor. Push and hold momentarily the knob on the control panel marked "EMERGENCY BRAKE RELEASE" **(See Figure 3-3)**. Doing so will allow air pressure from the trailer reservoir to release the spring brakes. Pulling the knob out will dump this air, engaging the spring brakes. If left in the "IN" position, the valve will automatically reset (pop out) once a tractor is coupled to the trailer.

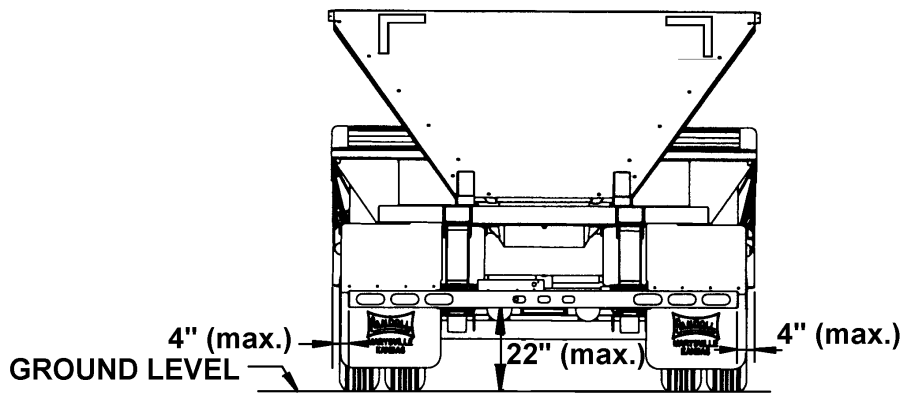

REAR VIEW OF TRAILER

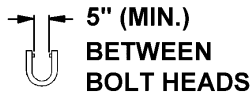

VIEW A-A

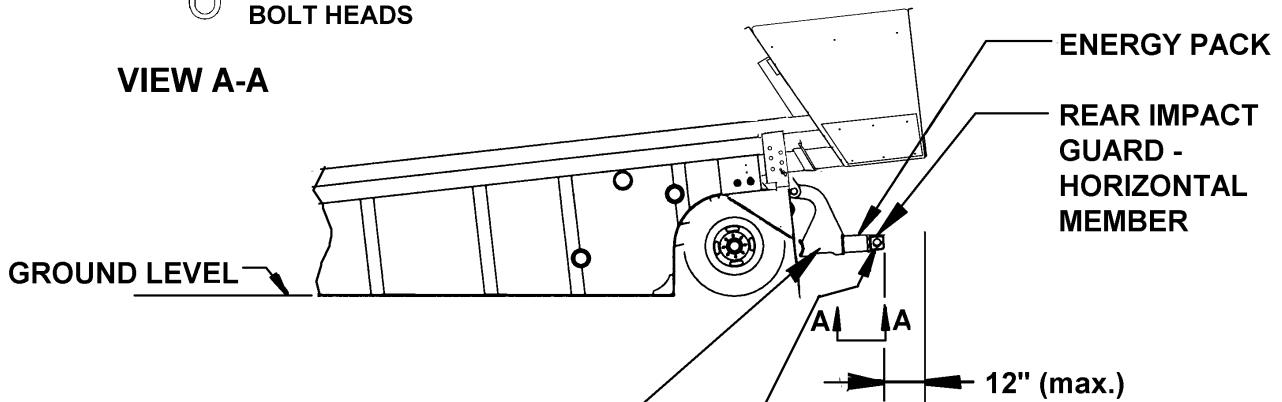

WARNING
IN THE EVENT OF COLLISION
OR DAMAGE TO BUMPER OR
ENERGY PACK, REPLACEMENT
IS MANDATORY BEFORE
FURTHER OPERATION OF THE
TRAILER
103056

WARNING DECAL TO BE
LOCATED ON REARWARD
CURBSIDE OF REAR IMPACT
GUARD AS SHOWN.

LANDOLL CORPORATION
1900 NORTH
MARYSVILLE, KS 66508-0111
MANUFACTURED IN: _____ (MO/YR)
DOT
103055

CERTIFICATION DECAL TO BE
LOCATED ON FORWARD FACING
SURFACE, 12 INCHES FROM
CURB END OF GUARD.

SIDE VIEW OF TRAILER

Figure 3-5 Rear Impact Guard System

3-14 AIR RIDE OPERATION

3-14.1 Trailer air pressure must be maintained above 65 PSI before operating. This enables the "PROTECTION VALVE" to maintain safe air brake pressure during suspension system air loss.

CAUTION

IF SUSPENSION AIR LOSS SHOULD OCCUR, COMPLETELY DEFLATE SUSPENSION AND TEMPORARILY OPERATE ON THE AIR SPRINGS INTERNAL RUBBER BUMPERS. CAREFULLY PROCEED TO THE NEAREST TRAILER SERVICE FACILITY. TO DEFLATE THE AIR SUSPENSION, DISCONNECT THE LOWER CONNECTION ON THE LINKAGE OF THE AUTOMATIC AIR VALVES. ROTATE THE VALVE CONTROL ARMS DOWN ABOUT 45° TO EXHAUST THE AIR. TO RESTORE TO NORMAL OPERATION, SIMPLY REVERSE THE PROCEDURE.

3-15 REAR IMPACT GUARD SYSTEM

Vehicle standards FMVSS No. 224, Rear Impact Protection, requires all trailers manufactured after January 26, 1998 shall be equipped with a rear impact guard certified by the manufacturer as meeting FMVSS No. 223, Rear Impact Guards. The guard, or bumper, (**See Figure 3-5**), meets the following requirements:

- **minimum of 4 inches vertical height**
- **extend laterally to within 4 inches of the sides of the trailer**
- **ground clearance of no more than 22 inches**
- **placed no more than 12 inches from the rear of the trailer.**
- **capable to deflect 5 inches.**

The standard also specifies minimum force and energy absorption requirements for the guard. A DOT decal certifies that the guard meets FMVSS No. 223 and 224 standards. The decal is placed **and must remain at all times** on the forward facing surface of the guard, 12 inches inboard of the curb side and of the guard. **See Figure 3-5** for location of decals.

Replace any component that does not allow the above minimum requirements to be met. Any hardware that holds the rear impact guard and becomes damaged or becomes loose shall be removed and replaced. The 3/4" grade 8 screws that hold the bumper energy pack shall be loctited and torqued to 280 ft.-lbs.

DANGER

ALWAYS CHECK THE CONDITION OF THE REAR IMPACT GUARD SYSTEM. IF GUARD SYSTEM HAS BEEN DAMAGED, IT MUST BE REPLACED. FAILURE TO MAINTAIN GUARD SYSTEM MAY RESULT IN INJURY OR DEATH TO OTHERS.

3-16 COLD WEATHER OPERATION

3-16.1 Cold weather causes lubricants to congeal, insulation and rubber parts to become hard, which may lead to problems found in bearings, electrical systems, and air systems. Moisture attracted by warm parts can condense, collect and freeze to immobilize equipment. The truck/trailer operator must always be alert for indicators of cold weather malfunctions.

3-16.2 During any extended stop period, neither the service nor parking brake should be used as they can freeze up. Use wheel chocks to secure the vehicle from moving.

3-16.3 Check all structural fasteners, air system fittings, gaskets, seals and bearings for looseness that can develop due to contraction with cold. Do not over-tighten.

3-16.4 Check tire inflation. Tire inflation decreases when the temperature decreases.

3-16.5 Periodically check drain holes in the bottom of the relay valve (for trailers with air brakes) and storage compartments. They must be open at all times to avoid moisture entrapment.

3-17 HOT WEATHER OPERATION

3-17.1 Hot weather operation can cause expansion of parts, resulting in tightening of bearings, fasteners, and moving parts. Failure of gaskets or seals can occur.

3-17.2 The trailer should be parked in the shade if possible. Long exposure to the sun will shorten service life of rubber components (i.e., tires, light and hose grommets, hoses, etc.) and paint life.

3-17.3 Check tire pressure early in the day before beginning operations while the tire is cool. Put all valve stem caps back on after checking.

3-17.4 If the area is extremely humid, protect electrical terminals with ignition insulation spray. Coat paint and bare metal surfaces with an appropriate protective sealer.

3-17.5 For trailers with air brakes, the use of a filter-lubricator in the towing vehicle's air delivery system is recommended.

4-1 GENERAL

This section contains instructions necessary for proper maintenance of the trailer. The trailer is designed for years of service with minimal maintenance. However, proper maintenance is important for durability and safe operation and is an owner/user responsibility.

4-2 MAINTENANCE SCHEDULE

Trailer maintenance includes periodic inspection and lubrication. **Table 4-2, Maintenance Schedule**, lists the recommended maintenance and lubrication tasks by time interval and by accumulated mileage (use whichever occurs first).

4-2.1 Inspection



OPERATING THE TRUCK OR TRAILER WITH DEFECTIVE, BROKEN OR MISSING PARTS MAY RESULT IN SERIOUS INJURY OR DEATH; DAMAGE TO THE TRUCK/TRAILER, ITS CARGO, OR PROPERTY IN ITS PATH.

Inspect the towing vehicle, the trailer, and trailer parts periodically for damage or signs of pending failure. Damaged or broken parts must be repaired or replaced at once. Determine the cause of any binding, at once. Correct the problem before using the towing vehicle or trailer.

4-2.2 Lubrication. See **Table 4-1** for lubricant required for axles. During inspections of the trailer, if lubricants are found to be fouled with dirt or sand, those parts should be cleaned with solvent, dried, and relubricated immediately. Dirt in a lubricant forms an abrasive compound that will wear parts rapidly.



PAINT THINNER AND OTHER SOLVENTS ARE FLAMMABLE AND TOXIC TO THE EYES, THE SKIN, AND THE RESPIRATORY TRACT. AVOID SKIN AND EYE CONTACT. GOOD GENERAL VENTILATION IS NORMALLY ADEQUATE. KEEP AWAY FROM OPEN FLAMES OR OTHER COMBUSTIBLE ITEMS.

4-3 MAINTENANCE PROCEDURES

4-3.1 Repair Parts. Repair parts are illustrated and listed in the parts manual. Replacement of parts due to wear is determined by examination and measurement.

4-3.2 Tools and Equipment. Tools, equipment, and personnel normally found in a facility capable of making truck repairs will be adequate for maintenance of the trailer. No other special tools or equipment should be necessary.

4-3.3 Standard Torque Values. Tables 2-2 and 2-3 list torque values for standard hardware and is intended as a guide for average applications involving typical stresses and mechanical surfaces. Values are based on the physical limitations of clean, plated, and lubricated hardware. In all cases, when an individual torque value is specified, it takes priority over values given in this table. Replace original fasteners with hardware of equal grade.

4-3.4 Cleaning

a. Wash trailer to remove all accumulated dirt and grime.

b. Use any mineral spirits paint thinner (or its equivalent) to remove grease and oil from all parts of the trailer. Rinse degreasing solution off with cold water.

c. Inspect trailer for cause of any reported troubles.

d. Scrape, sand, prime, and repaint areas where finish is missing or where there is evidence of corrosion.

e. Replace any missing or illegible decals. Replace any missing or damaged reflective tape.

f. Use the Troubleshooting Guide to check for "SYMPTOMS" and "PROBLEMS" of any trailer system not functioning correctly. Administer "REMEDY" according to the right-hand column of the Troubleshooting guide.

g. After disassembling any components, thoroughly clean dirt and old lubricant from all parts. Do not use a wire brush on any bearing parts or surfaces — use a stiff bristle brush. Do not use compressed air, or spin bearing parts when cleaning. These practices can throw solvents, dirt, or metal particles into your eyes. Dry clean parts with lint free, clean, soft, absorbent, cloth or paper. Wash and dry hands.

h. Inspect seals, seal wiping surfaces, any bearing caps, and bearing cones for wear, pitting, chipping, or other damage.

4-4 FRAME AND DECKS

The trailer should be thoroughly checked daily for cracks or material fatigue. Cracks will normally show best under loaded conditions. If any cracks or breaks are found, immediately contact Landoll Corporation for recommended repair. Any defective parts must be replaced immediately.

4-5 ELECTRICAL SYSTEM

4-5.1 Maintenance of the electrical system consists of inspection and minor servicing. Any wire, connection or electrical component showing signs of corrosion, wear, breakage or unraveling must be repaired or replaced.

4-5.2 Frayed or unraveling wire must have the defective section removed and replaced with wire of the same color and gauge. Seal all connections and insulate.

4-5.3 Corroded terminals must have the corrosion removed, source of corrosion neutralized and the terminals resealed, protected and insulated.

4-5.4 Fuse or circuit breaker burn-out or "blow-out" usually indicates an electrical short-circuit, although a fuse can occasionally fail from vibration. Insert a second fuse or reset the breaker. If this fuse immediately burns out or the breaker trips, locate the cause of the electrical short and repair.

4-5.5 Lights with a repeated lamp burn-out usually indicates a loose connection, poor system ground, or a malfunctioning voltage regulator. Locate the source of the problem and repair. System grounds must be grounded to bare metal surfaces. Paint, grease, wax, and other coatings act as insulators. Replacement lamps must be equivalent to the factory installed lamp.

4-6 BRAKE SYSTEM MAINTENANCE

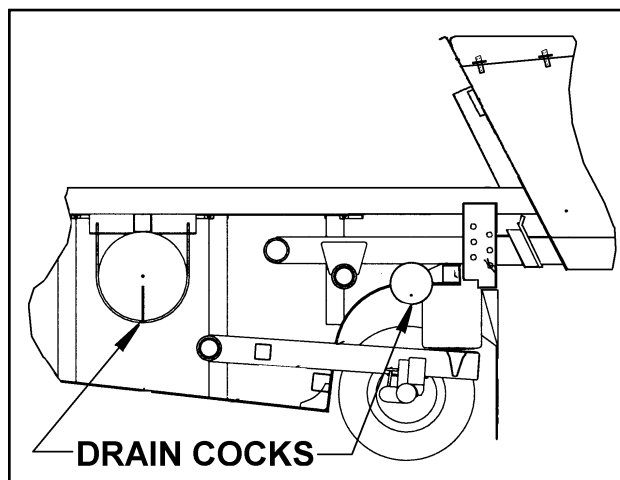

Figure 4-1 Drain Cock Locations

WARNING

USE GREAT CARE IF WHEELS OR BRAKE DRUMS MUST BE TOUCHED OR HANDLED. THEY MAY BE VERY HOT AND CAN CAUSE SERIOUS INJURY.

4-6.1 General

a. Check air hoses for chafing, bends, kinks, or damaged fittings. Replace defective hoses.

b. Check the brake system for loose, missing, deformed, or corroded fasteners. Replace and tighten defective hardware.

c. Check brake linings for excessive wear or distortion.

d. Drain air reservoir daily. A drain cock on the bottom of each air reservoir vents the tank to drain collected water and oil. If held open, air pressure in the tanks is relieved, causing the emergency or parking brakes to be applied (**See Figure 4-1**).

4-6.2 Air Brake Chamber Maintenance

Repair or replace faulty units. Check the condensation holes on the underside of the brake chambers to make sure they are open. The front and rear brake chambers each have two brake chambers - a service chamber and an emergency chamber or spring chamber. The spring chamber should not be serviced. Replace entire unit if spring chamber becomes faulty. Examine yoke pin for wear and replace as necessary.

 **WARNING**

WHEN CRAWLING UNDER THE TRAILER IS NECESSARY, CHOCK ALL WHEELS OF THE TRAILER AND TRUCK. WHEN JACKING IS NECESSARY, CHOCK ALL WHEELS AND SUPPORT THE TRAILER FRAME WITH JACK STANDS SUFFICIENT TO WITHSTAND THE WEIGHT OF THE TRAILER AND LOAD. FAILURE TO TAKE ADEQUATE SAFETY MEASURES CAN RESULT IN SERIOUS PERSONAL INJURY OR DEATH.

 **WARNING**

THE SPRING BRAKE CHAMBER EMPLOYS A SPRING WITH HIGH FORCES. SERVICE SHOULD NOT BE ATTEMPTED. SERIOUS INJURY OR DEATH MAY RESULT.

a. Caging the Power Spring

1. Chock the trailer wheels.
2. Remove dust cap from spring brake chamber.
3. Remove the release bolt from its holding brackets and insert it into the spring brake chamber. **DO NOT USE AN IMPACT WRENCH TO CAGE THE SPRING BRAKE.**
4. Turn the bolt until the spring brake is caged. This should be 2-1/4 to 2-1/2 inches of release bolt extension.
5. The brakes should now be totally released. Do not operate loaded trailer with brake manually released.
6. To reset the spring brake, turn the release bolt until the spring is released. Remove the release bolt and store it in its brackets.
7. Snap the dust cap back in place on the chamber.

b. Removal

1. Chock all tractor and trailer wheels and drain the air system.
2. Mark the brake chamber for proper air line port alignment for reassembly.
3. **CAGE THE POWER SPRING** following the steps outlined in **Section 4-6.2a.**
4. Disconnect the slack adjuster from the connecting rod by removing the clevis pin (**See Figure 4-4**).
5. Mark all air service lines for proper reinstallation and disconnect from the brake chamber.
6. Remove the brake chamber from the axle brackets.

c. Installation

1. **CAGE THE POWER SPRING** following the steps outlined in **Section 4-6.2a.**
2. Position the inlet ports by loosening the service chamber clamp bands and rotating center housing such that ports are located according to alignment marks made during disassembly, then retighten the clamp bands.
3. Position the breather hole in the downward facing position by loosening the clamp bands on the spring brake chamber and rotating the chamber housing until the breather hold faces downward. Retighten the clamp bands.
4. Remount the brake chamber on the axle brackets and reconnect the air service hoses and the slack adjuster connecting rod (**See Figure 4-4**).

IMPORTANT

BE SURE THE SERVICE LINE ON THE SERVICE CHAMBER PORT AND THE EMERGENCY LINE IS ON THE SPRING BRAKE PORT.

- d.** Check for leakage by charging the air system to a minimum of 90 psi and applying soap suds to the brake chamber and connections. If a growing bubble is detected or bubbles are blown away, locate the source of the leak and repair.
- e.** Insure that the clamp band is properly seated and tight **before** uncaging the power spring.

4-6.3 Emergency Relay Valve Maintenance

Every 3600 operating hours, 100,000 miles, or yearly, the Emergency Relay Valve should be disassembled, cleaned, and lubricated by a trained technician.

WARNING

REPAIR OR REPLACEMENT OF THE RELAY/EMERGENCY VALVE IS A COMPLEX OPERATION AND SHOULD BE PERFORMED BY TRAINED SERVICE PERSONNEL. CONTACT A LANDOLL AUTHORIZED SERVICE CENTER OR THE LANDOLL FACTORY FOR SERVICING.

4-6.4 Brake Assembly Maintenance

The brake assemblies should be inspected and adjusted every 2,000 miles or monthly. Examine the brake linings visually to locate the lining showing the greatest amount of wear. The wheel and drum should be removed and the linings replaced if the thinnest portion of the lining is $\frac{3}{8}$ in. (9.5 mm) or less. Do not allow the linings to wear thin enough that the lining rivet contacts the drum. (See Figure 4-2).

WARNING

DO NOT ALLOW GREASE TO CONTACT BRAKE LININGS AS THIS COULD RESULT IN REDUCED BRAKING PERFORMANCE.

a. Brake Adjustment

This trailer is equipped with automatic slack adjusters which compensate for brake lining wear and keep brakes adjusted. Brakes should not be adjusted manually except when relining brakes.

b. Disassembly for Brakes (See Figure 4-3)

1. Release brakes and back off slack adjuster.
2. Remove slack adjuster lock ring and slack adjuster.
3. Remove drum assembly (See Figure 4-5).
4. Disengage the roller retainers from the rollers.
5. Press down on the bottom brake shoe and remove the lower cam roller. Lift the top shoe and take out the top cam roller.
6. Lift out the shoe retractor spring, which is now free of tension.
7. Swing the lower shoe back approximately 180° to relieve the tension on the shoe keeper springs. Remove the springs and slip the shoes off the anchor pins.
8. Remove camshaft lock ring, spacer washer(s) and camshaft.
9. After removing the shoes, completely inspect all brake components, servicing as necessary.

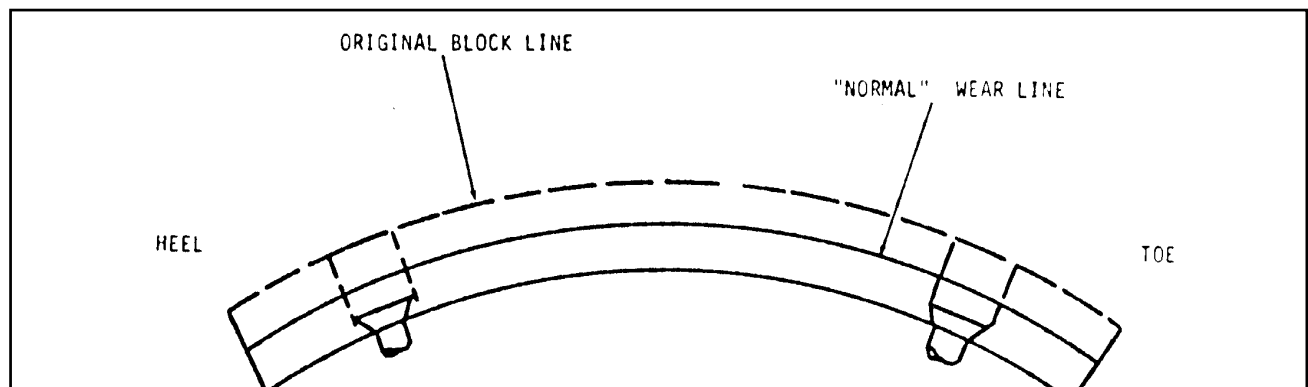

Figure 4-2 Brake Lining Wear

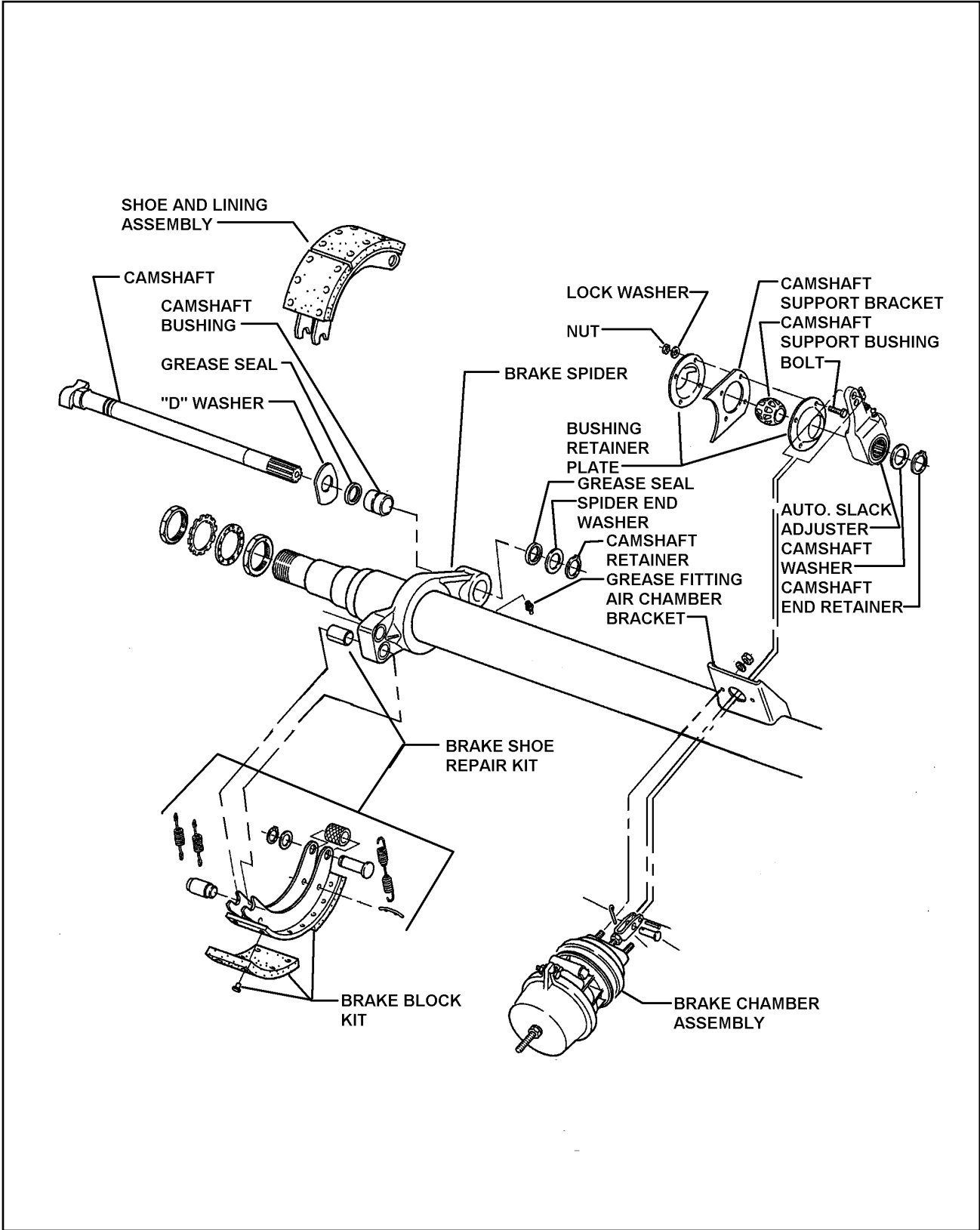

Figure 4-3 Axle and Brake Assembly

c. **Reassembly for Brakes (See Figure 4-3)**

1. Install new anchor pin bushings, camshaft bushing, and camshaft seals into the spider.

IMPORTANT

WHEN INSTALLING CAMSHAFT SEALS, THE SEAL ON THE SLACK ADJUSTER SIDE IS INSTALLED FACING INTO SPIDER. THIS ALLOWS GREASE TO PURGE OUTSIDE THE BRAKE ASSEMBLY WHEN GREASING THE CAMSHAFT BUSHING.

2. Install cam roller, retainer clip and retractor spring retainers onto the brake shoes.
3. Install 1/8" thick camshaft washer onto the camshaft.
4. Install the camshaft into the spider. Install spacer washer and lock ring on camshaft before sliding the camshaft through the camshaft support bracket. Install the slack adjuster, washer and lock ring.

5. Install the brake keeper springs onto the shoes. Install shoes onto the spider by placing shoes in place on the anchor pins, then "wrap" the two shoes into place about the spider.
6. Install the shoe retractor spring onto the shoes.
7. Connect slack adjuster to brake chamber pushrod.
8. Adjust automatic slack adjuster as outlined in **Section 4-6.5**.

4-6.5 Automatic Slack Adjuster

The trailer automatic slack adjusters provide the means for routine brake adjustment to compensate for lining wear. Inspect slack adjusters every 2,000 miles to assure correct operation.

a. **Operational Check (See Figure 4-4)**

1. Block wheels to prevent vehicle from rolling.
2. Check that the push rod is fully retracted, apply air to release spring brake.
3. Turn adjustment hex counterclockwise to create an excessive clearance condition. (A ratcheting sound will occur.)

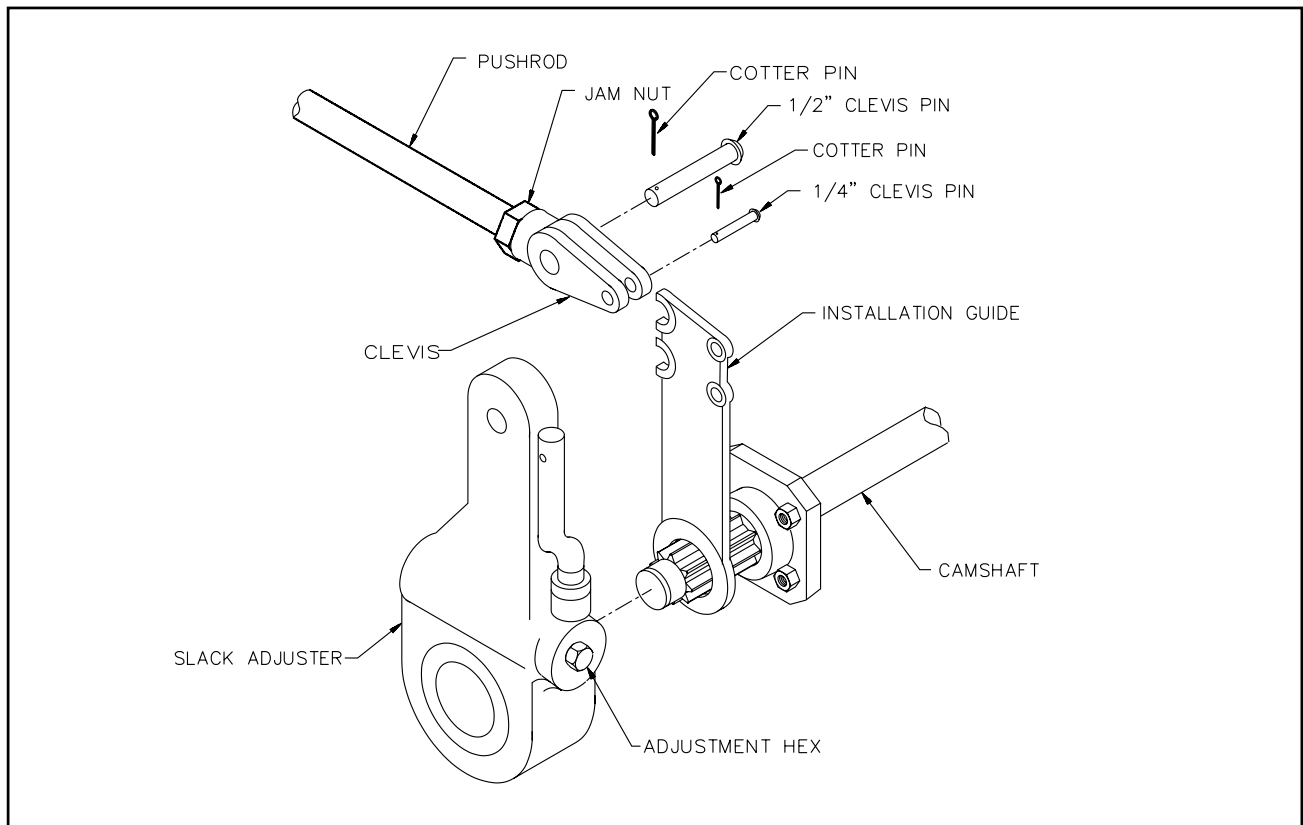

Figure 4-4 Slack Adjuster

4. Make a full service brake application. On release, allow sufficient time for brake to fully retract. During the brake release, observe rotation of the adjustment hex (attach a wrench on the hex to make this movement easier to see). This rotation indicates that an excessive clearance condition has been determined by the slack adjuster, and it is making an adjustment to compensate. On each subsequent brake release the amount of adjustment and push rod travel will be reduced until the desired clearance is achieved.
5. The push rod stroke should be 1 1/2" to 2" with an 80 to 90 PSI service brake application.
6. Measure the movement of the push rod from the completely released position to the applied position by marking the push rod where it exits the air chamber before and after application.
7. If the brakes have been running tight, the control arm location should be checked.

WARNING

IF THE ADJUSTER APPEARS NOT TO BE OPERATING, CHECK THE OTHER BRAKE COMPONENTS FOR PROPER FUNCTION AND ELIMINATE ANY BINDING. RECHECK THE AUTOMATIC SLACK ADJUSTER. IF THE ADJUSTER IS NOT FUNCTIONING, THE UNIT MUST BE REPLACED BECAUSE FAILURE OF PROPER ADJUSTMENT FUNCTION WILL RESULT IN LOSS OF BRAKES.

b. Replacing Slack Adjuster (See Figure 4-4)

1. Chock wheels to prevent vehicle from rolling. Release spring and service brake. Air chamber push rod must be **fully released**.
 2. To maintain a fully released parking brake, a minimum of 105 psi reservoir pressure must be maintained. If air pressure is not available the spring brake must be manually caged.
3. Remove the existing slack adjuster and clevis - **DO NOT REMOVE EXISTING JAM NUT**.
 4. Install the new clevis (with 1/2" pin) onto the push rod up to the jam nut -**DO NOT TIGHTEN JAM NUT**.
 5. Fit the installation guide over the s-cam splines so the 1/2" pin slots face the air chamber.
 6. Swing the guide into the clevis until the appropriate slot totally engages 1/2" pin.
 7. Observe the guide pointer arrow:
If the guide pointer is above the clevis pointer, adjust clevis CCW for alignment.
If the guide pointer is below the clevis pointer, adjust clevis CW for alignment.
 8. Reposition clevis until the guide pointer aligns with the clevis pointer.
 9. Verify by engaging 1/4" pin through the clevis and guide.
 10. Tighten jam nut to 50 ft.-lbs. torque min.
 11. Remove the guide from cam shaft.
 12. If the push rod threads extend through the clevis more than 1/16", remove clevis and cut rod to length.
 13. If the push rod is not fully engaged in clevis body, install a new push rod - cut to length.
 14. Install the slack adjuster on the cam shaft.
 15. Rotate the manual adjuster shaft CW until the slack adjuster arm holes align with the clevis. Install 1/2" and 1/4" pins and cotter pins.
- c. Adjusting Slack Adjuster**
1. Rotate the manual adjuster clockwise until brake shoes contact drum.
 2. Back off manual adjuster 1/2 turn. (counterclockwise)
 3. Manually uncage the spring brake.
 4. Build up vehicle air pressure.
 5. Fully apply and release the brakes several times to check for adequate clearance to all adjacent components.
 6. Measure the distance from air chamber to 1/2" pin. Apply brakes with 100-105 psi air pressure and remeasure distance to 1/2" pins.
 7. The stroke (difference of these two measurements) must be less than 2 inches.

4-7 HUB AND DRUM MAINTENANCE

WARNING

FAILURE TO REPLACE FAULTY BRAKE DRUMS WILL RESULT IN AN UNRELIABLE BRAKING SYSTEM, AND MAY LEAD TO AN ACCIDENT.

4-7.1 Clean and inspect the brake drums whenever relining the brakes. To be suitable for further service, the brake drum should pass the following checks.

- a. The brake surface should be free of scoring, excessive heat checks and cracks.
- b. The brake surface diameter should be within the maximum diameter cast or stamped on the drum.
- c. The mounting holes and pilot must be round and true.
- d. The mounting surface must be clean and flat.

4-7.2 It may be necessary to turn or resurface the braking surface to remove small heat checks or other surface defects resulting from normal use.

a. The maximum diameter cast into the back plate portion of the brake drum is the maximum diameter or discard diameter to which the brake drum may be turned or worn and still be usable. If any portion of the brake surface exceeds the maximum diameter it must be discarded. The maximum is .120 over the nominal new diameter unless stated otherwise on the casting. The maximum diameter cast into the brake drum supersedes all published information.

b. When resurfacing a drum, allow at least 0.040 inches under the maximum diameter for additional wear.

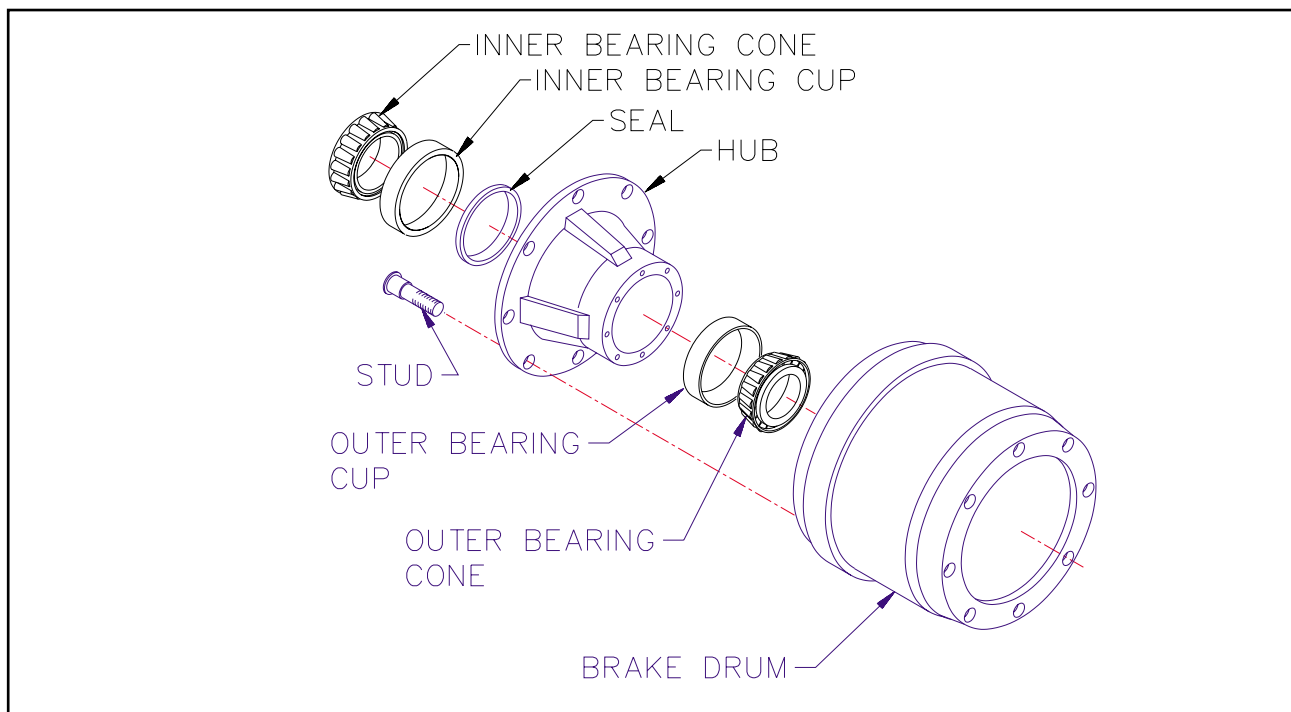

Figure 4-5 Hub and Drum Assembly

WARNING

TURNING A BRAKE DRUM BEYOND 0.040 INCHES UNDER THE MAXIMUM DIAMETER WILL RESULT IN A WEAKER BRAKE DRUM AND MAY RESULT IN AN ACCIDENT.

- 4-7.3** Replacement of the brake drum is required if any of the following conditions exist:
- The brake drum is cracked.
 - The brake surface is heat checked, grooved or worn beyond the rebores limit or the maximum diameter.
 - The back plate is cracked.
 - The bolt holes are elongated.
 - The brake drum has been severely overheated.
 - The brake drum is out-of-round.

CAUTION

REPLACE BRAKE DRUMS IN PAIRS TO ACHIEVE THE SAME BRAKING POWER ON BOTH WHEELS AND MAINTAIN AN EVEN BRAKING LOAD ON THE AXLE. FAILURE TO DO THIS MAY SIGNIFICANTLY REDUCE THE PERFORMANCE, SERVICE LIFE, AND/OR SAFETY OF YOUR VEHICLE.

- 4-7.4** Replace the hub and drum as follows (See Figure 4-5):
- Remove the brake drum. It may be necessary to release the slack adjuster.
 - Remove hub cap and catch lubricant in a pan.
 - Remove outer spindle nut, spindle locking washer, inner spindle nut, and bearing. Remove hub from axle.
 - Using an appropriate driver, remove inner bearing cone, and seal.
 - Using an appropriate driver, remove bearing cups from hub.

- Check that the hub cavity is clean.
- If the hub is to be reused, clean it thoroughly.
- Insert bearing cups into the hub.
- Install the drum to the hub or wheel unless the drum is outboard mount.
- Clean the mounting surfaces with a good grade commercial cleaner and soft rag. Dry all component parts with a clean, absorbent cloth or paper. Lubricant will not adhere to surfaces wet with solvent.
- Make sure the drum seats flat against the hub flange and mates properly with the hub pilot. There should be no interference between the brake drum pilot chamfer and the corner radius on the hub.
- Install inner bearing, cone, and seal.

IMPORTANT

DO NOT MIX NEW CUPS WITH OLD CONES OR NEW CONES WITH OLD CUPS.

- If studs are marked "R" or "L", right hand (R) hubs should be installed on the curbside of the vehicle, left hand (L) hubs should be installed on the driver side.

WARNING

FAILURE TO USE THE CORRECT STUD ON THE CORRECT SIDE MAY CAUSE LOOSENING OF THE HUB STUDS DURING OPERATION, RESULTING IN LOSS OF A WHEEL.

- Place the hub or wheel over the axle spindle being careful to align the hub bore with the axle. Do not damage the seal. Support the hub assembly until the outer bearing cone and spindle nut are installed, to avoid damaging the seal.
- Install the outer bearing cone and inner spindle nut, tightening the nut until it is snug against the outer bearing cone. Remove the hub support allowing the hub to rest on the bearings.
- Install and adjust bearings (See Section 4-8).

- q. Install the hub cap with the proper gasket. Tighten the cap screws of the hub cap to 15 to 20 ft-lbs. of torque.
- r. Remove the filler plug and fill the hub cavity to the recommended level with a gear type oil.

- s. Place the drum over the hub and brake shoes being careful not to damage the threads on the studs. Make sure the drum seats flat against the hub flange and mates properly with the hub pilot. There should be no interference between the brake drum pilot chamfer and the corner radius on the hub. If interference exists, the hub will not be able to function properly.

4-8 WHEEL BEARING LUBRICATION AND ADJUSTMENT

With trailer sitting level, the oil level must be checked daily and maintained between the "ADD" and "FULL" lines on the hub cap window. Check for cracked windows, missing filler plugs, and oil leaks. Add hub oil through the "POP-IN" filler plug located in the center of the hub windows. Reinstall the "POP-IN" plugs after filling each hub.

4-8.1 Adjustment

- a. With a drain pan under the hub cap, remove the hub cap assembly allowing oil to drain.
- b. Lift the wheel off of the ground.
- c. Adjust slack adjuster to eliminate brake drag during tire/wheel rotation (See Section 4-6.5c.).

- d. Remove outer spindle nut and lock washer (See Figure 4-3).
- e. Rotate the tire by hand and tighten the inner nut until there is a slight bind. Back off the inner spindle nut 1/4 turn (3/8 turn max.) to allow free rotation of wheel.
- f. Install lock ring. Lock ring must engage pin on inner adjusting nut. Nut must engage nearest pin hole.
- g. Install tab washer and outer spindle nut. Torque outer spindle nut to 250 (min.) - 300 (max.) ft-lb. Bend 3 tabs over outer nut flats to secure.
- h. Install the hub cap with a new gasket and fill with oil to the full mark (See Table 4-1).
- i. Check hub oil level after the wheel has set level in one position for a few minutes to allow the oil to work into the bearings.

4-9 SUSPENSION MAINTENANCE

4-9.1 Air Ride Suspension

- a. Physically check all nuts, bolts, and air line fittings for proper torque (see torque chart below).

AIR SUSPENSION TORQUE CHART			
Size	5/8"-11	*3/8"-16	*3/4"-16
Torque in Ft. Lbs.	110 to 130	10 to 15	35

* Air Spring Connections Only.

- b. Check all other suspension components for any sign of damage, looseness, wear or cracks.

- c. With trailer on level surface and air pressure in excess of 65 psi, all air springs should be of equal firmness. The height control valve on right side of front axle controls all air springs on tandem axle suspensions.
- d. The height control valve on right side of center axle controls ride height for all air springs on triple axle suspension.

4-9.2 Air Ride Height Adjustment. (See Figure 4-6 for parts identification).

- a. Before adjusting, the vehicle must be empty with the kingpin at operating height and have air supplied to the trailer.
- b. Disconnect linkage at the control arm and raise control arm to the "up" position, raising the trailer until a 14-3/4" block can be placed between suspension tube and frame (See Figure 4-6).

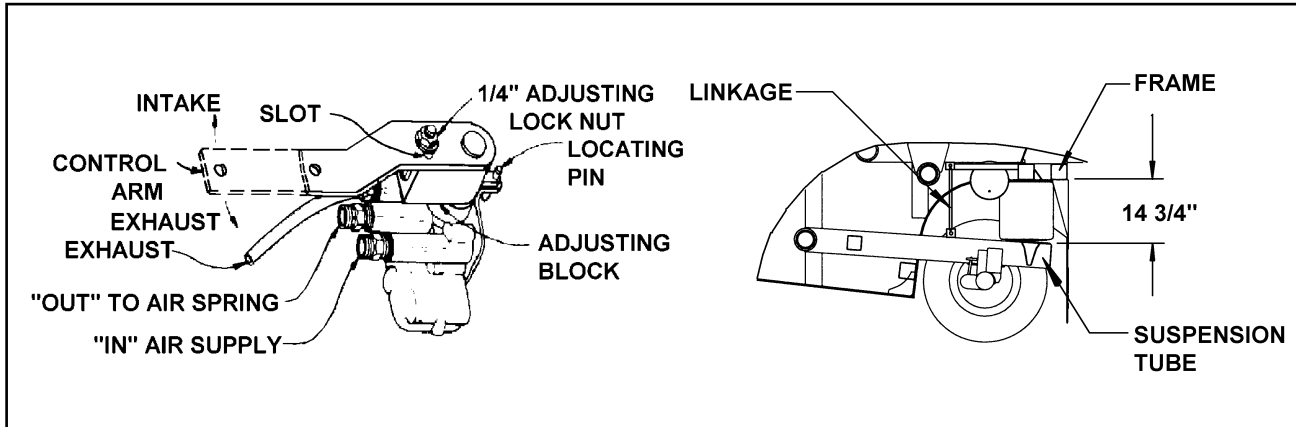

Figure 4-6 Ride Height Adjustment

c. Lower the trailer by exhausting air from the air springs by moving the control arm to the “down” position (about 45°) until the axle tube is resting on the block.

d. Loosen the 1/4" adjusting lock nut located on the adjusting block, allowing the control arm to move approximately 1 inch. Move the adjusting block until holes align, then insert locating pin. (See Figure 4-6).

e. Align the control arm linkage to the control arm lower bracket and retighten the 1/4" adjusting lock nut to 2-4 ft.lbs. The ride height valve should now be correctly adjusted.

f. Remove the locating pin.

g. The block can now be removed by using the height control valve as an improvised jack by disconnecting the control arm at the lower bracket and pushing the control arm to an “up” position.

h. Remove the block and reconnect the linkage. This allows the Automatic Height Control Valve to resume normal operation.

i. Check the air ride height periodically and adjust as needed.

j. These adjustments may vary with different tractor fifth wheel heights.

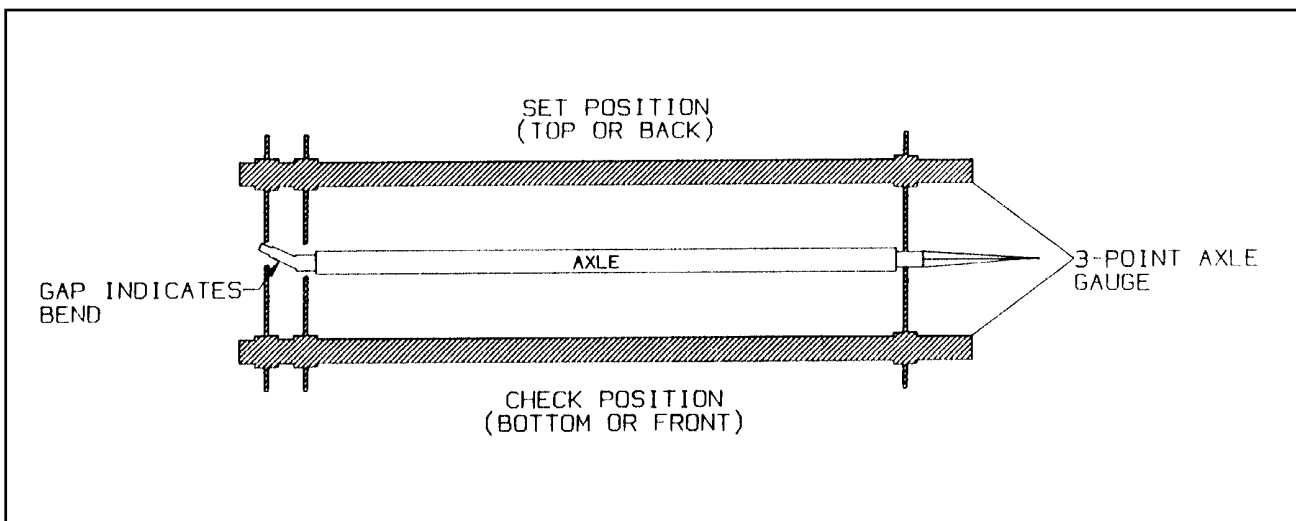

Figure 4-7 Checking Axle for Bend

4-10 ALIGNMENT

4-10.1 Wheel Alignment



TO PREVENT A LIFE THREATENING ACCIDENT:

1. SUPPORT TRAILER AND UNDERCARRIAGE SO TIRES ARE OFF THE GROUND.

2. SUPPORT THE TRAILER AND UNDERCARRIAGE ON JACK STANDS WITH SUFFICIENT CAPACITY TO SUPPORT THE TOTAL WEIGHT OF THE TRAILER AND ANY LOAD WHICH IT MAY BE CARRYING.

When trailer tires show signs of scuffing, feathering or uneven wear, examine the trailer for damaged suspension (frame, shocks, linkage, etc.), axle, wheel bearings and wheels. Proper wheel alignment and wheel bearing adjustment is essential for proper tire wear. The simplest form of checking wheel alignment "toe" is by running the trailer over a "SCUFF GAUGE". A scuff gauge reading of 16 feet or less per mile is considered satisfactory. If a scuff gauge is not readily available, or edge wear on one side of a tire is occurring signifying positive or negative camber, alignment can be checked as follows:

- a. Remove wheel, hub and bearing assemblies.
- b. Place a 3-point axle gauge against the front side of the axle, and adjust each axle gauge point to the axle. (Double point end against the inner and outer wheel bearing surfaces of the spindle being checked and the other point on the inner bearing surface on the other spindle.) (See Figure 4-7).

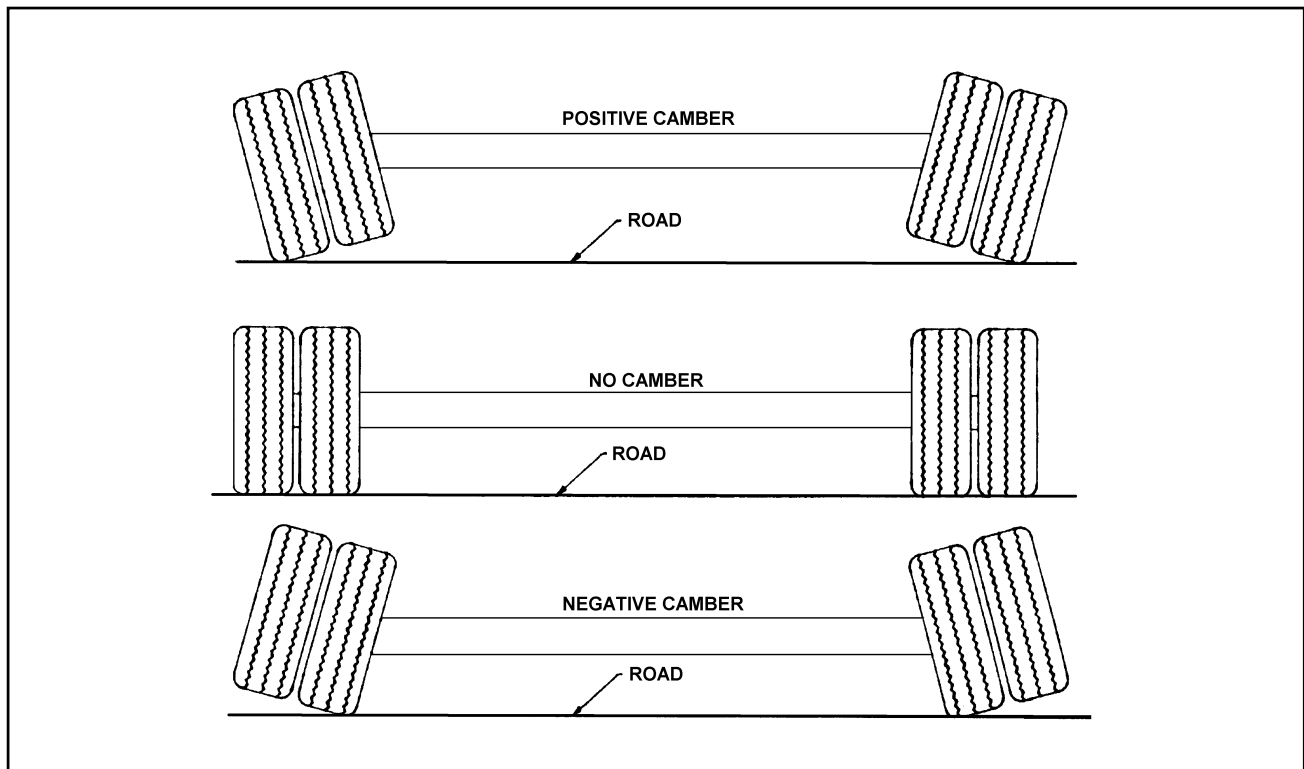

Figure 4-8 Examples of Camber

c. Move the axle gauge and place against the back side of the axle. If either of the points of double point end fails to touch the axle surface, a bent spindle is evident. A point gap of .015" or more is considered excessive tire "toe" and the axle must be replaced (See Figure 4-7).

d. Follow the same procedures as in Section 4-10.1 b. and c., except place the axle gauge above and below the axle. If gauge point gap is found, the axle has positive or negative camber. The trailer axle has no camber from the factory. If it is found to have positive or negative camber, axle replacement is necessary (See Figure 4-8 for examples of camber).

4-10.2 Axle Alignment

Proper axle to king pin alignment is necessary to obtain straight tracking. If axle alignment is off, "dog-tracking" occurs. Check alignment manually or by using a trailer alignment machine. In either case, a thorough inspection of the complete suspension must be performed and all defects corrected before aligning.

a. Manual Alignment Procedure

1. Position trailer on a firm and level surface. Insure that the undercarriage is in the rear most position. Eliminate any suspension binding due to sharp turns or unusual maneuvers.
2. Detach tractor from the trailer and jack the trailer up sufficiently to permit measuring from the underside of the trailer.
3. Suspend a plumb bob at axle height from the center of the king pin.
4. Measure (D) from the plumb bob to the center point on one end of the axle. Record this measurement (See Figure 4-9).
5. Measure (D1) to the other end of the axle in the same manner as in Step 4.. Record this measurement (See Figure 4-9).
6. It is usually necessary to set D about 1/8" shorter than D1 to insure proper trailer tracking on slope of road.
7. Loosen the nuts on the u-bolts attaching the axle to the suspension.
8. Slide the axle and u-bolts in the bracket on the suspension until proper alignment has been achieved.
9. Tighten the nuts on the u-bolts to 110 to 130 ft. lbs.
10. In all cases, all suspensions must be in good repair with no binding or other restrictions before the alignment process can be undertaken properly. All defective parts of the suspension or axles must be replaced immediately.

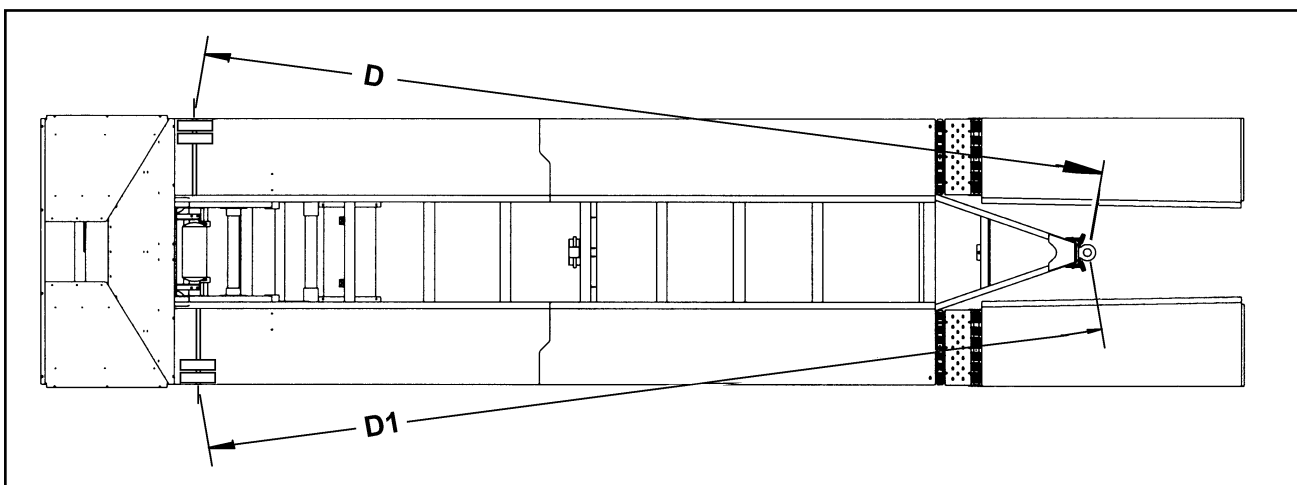

Figure 4-9 Checking Axle Alignment

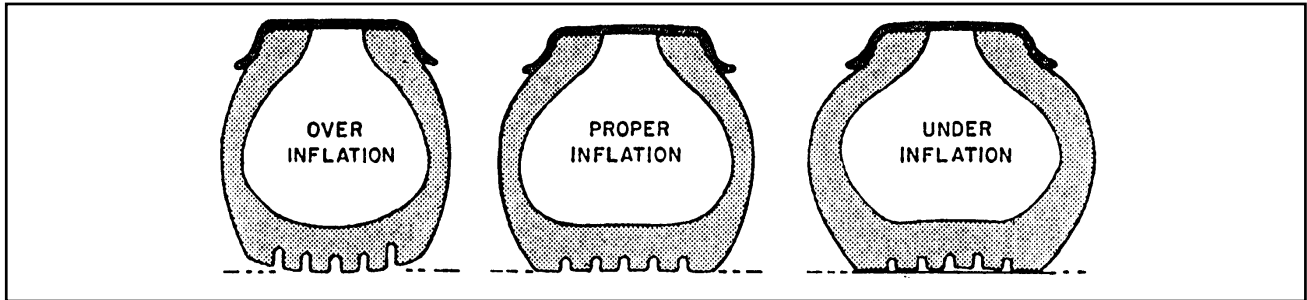

Figure 4-10 Tire Inflation Examples

4-11 TIRES

4-11.1 Tire Inflation. Tire inflation will cause tire to ground contact characteristics as shown in **Figure 4-10**. Tire inflation should be checked daily while the tire is cold, and during road stops. Checking the tire pressures while tires are hot will give a faulty increased pressure reading. Adjusting tire air pressure to the specified amount while tires are hot will produce improper tire to road contact and thus abnormal wear. Do not exceed cold inflation pressure listed on the trailer VIN plate. Exceeding cold inflation pressure will result in damaged tire bodies, rims, and wheels. Replace all valve stem caps when pressure checking/adjusting has been completed.

4-11.2 Tire Matching. Both tires on the same spindle must be the same size in order to properly distribute the load and braking forces between them. The tire must be mounted on a rim and properly inflated before measuring. If there is an allowable difference in size the smaller tire should be mounted to the inside position of the duals.

a. Tape Measuring Method: Measure around each tire on the tread surface. A maximum difference of 3/4" is allowed between the two mating tires of a dual (**See Figure 4-11**).

b. Straight Edge or String Method: (This method cannot be used if tire and wheel assemblies are not mounted on the axle.) Jack trailer up until the wheels are off of the ground. Hold a straight edge against the tires of both ends of an axle. A gap at one tire indicates a smaller tire. A maximum of 1/8" gap is allowed (**See Figure 4-12**).

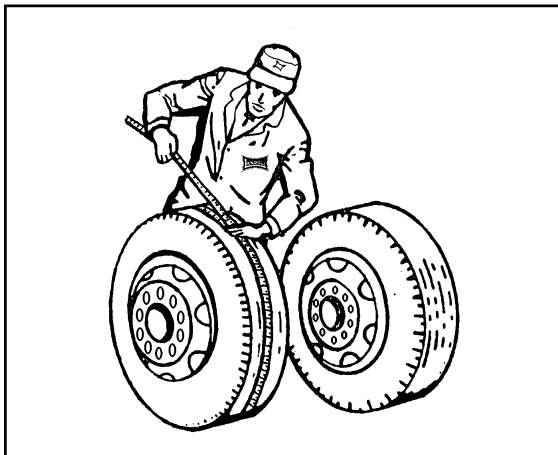

Figure 4-11 Measuring Tape Method

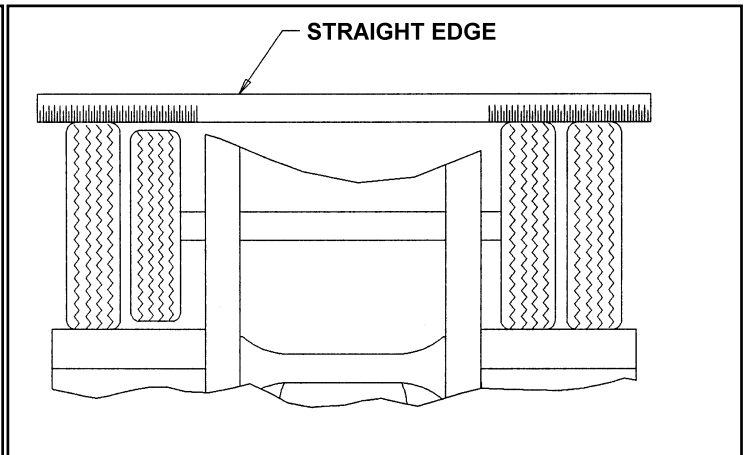

Figure 4-12 Straight Edge Method

4-12 WHEELS

4-12.1 Mounting Tire and Wheel (Hub Type)

a. Make sure that all mounting surfaces are clean and free of rust, dirt or paint. A wire brush may be used to clean these surfaces (See Figure 4-13).

b. Position the inner disc wheel over the studs, being careful not to damage the stud threads. Make sure that the disc wheel is flat against the mounting surface and that there is clearance between the disc wheel taper and brake drum.

c. For ball seat mounted wheels only, install the inner capnuts on the studs and tighten to fifty foot-pounds using the sequence illustrated in Figure 4-14. Make certain that the left-handed threads are installed on the driver side of the vehicle and the right-handed threads are installed on the curbside of the vehicle.

d. Tighten the inner capnuts to full torque of 450 to 500 foot-pounds using the sequence shown in Figure 4-14.

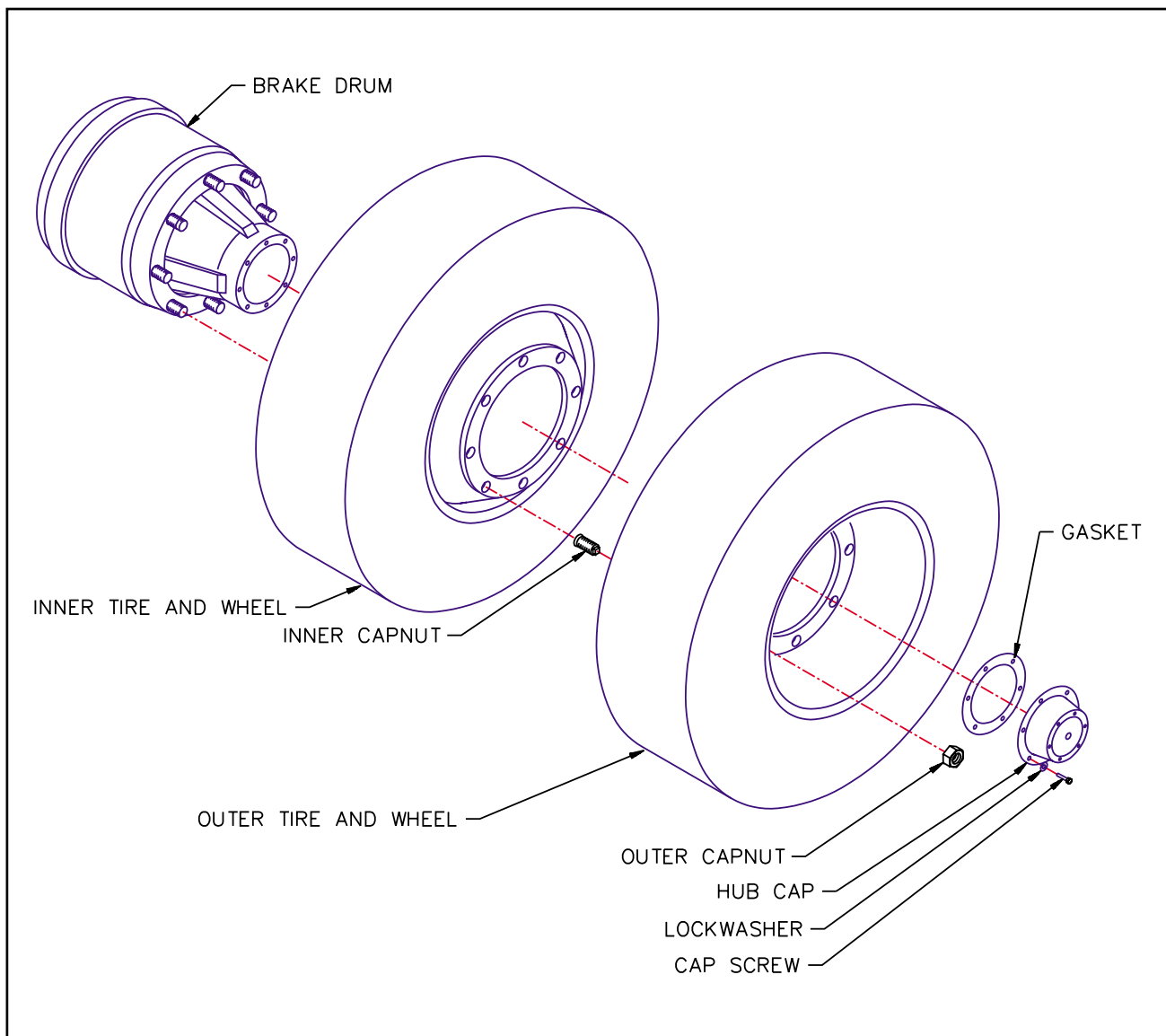

Figure 4-13 Mounting Tires and Wheels

e. For **pilot mounted wheels**, skip **steps c. and d.**

f. Position the outer disc wheel over the capnuts being careful not to damage the inner capnut threads. Be sure the valve stems for both the inner and outer tire are accessible.

g. Install the outer capnuts (ball seat) or flange nut (pilot mount) and tighten to 50 foot-pounds using the sequence in **Figure 4-14**. Then tighten to full torque of 450 to 500 foot-pounds for ball seat and 500 to 550 foot-pounds for pilot mount, using the same sequence.

h. Torque will drop after the first 50 to 100 miles of operation. Check the capnuts for proper torque after this interval and retighten them. Loosen the outer capnuts and retighten the inner and outer capnuts per **steps d. to g.**

! WARNING

USE A TORQUE WRENCH TO ASSURE PROPER TORQUE. INSUFFICIENT TORQUE CAN CAUSE STUD BREAKAGE AND DAMAGE WHEEL PILOTS. OVERTORQUE CAN OVERSTRESS THE STUDS AND STRIP THE THREADS.

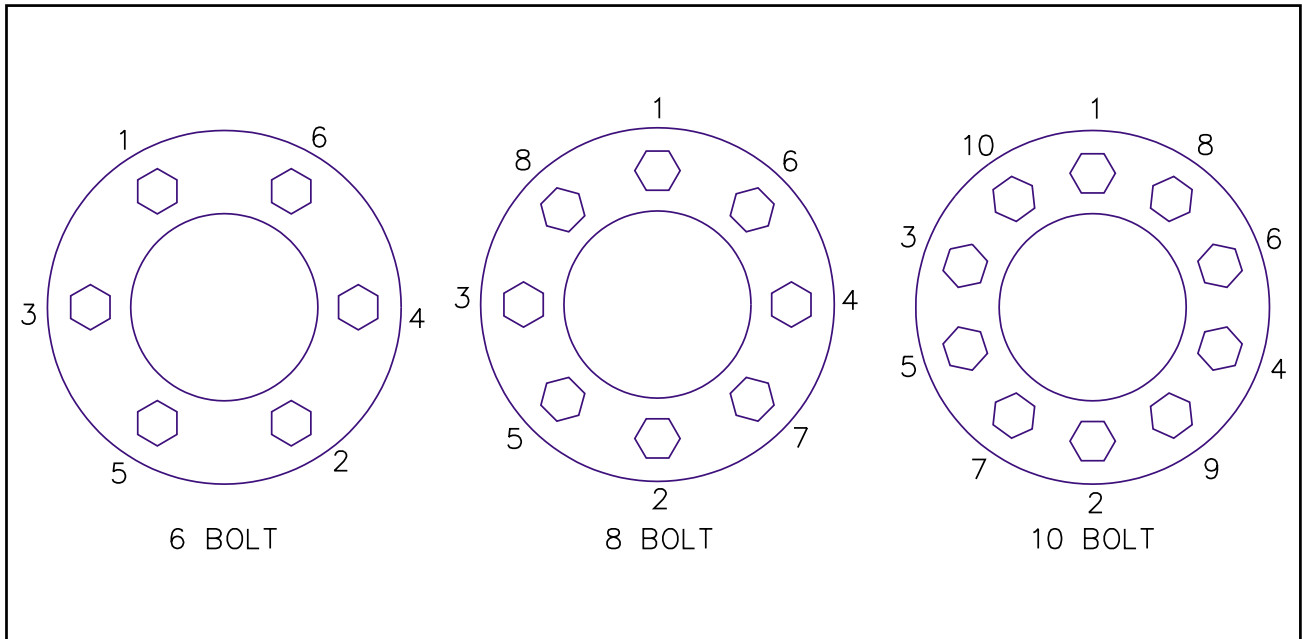

Figure 4-14 Stud Tightening Sequence

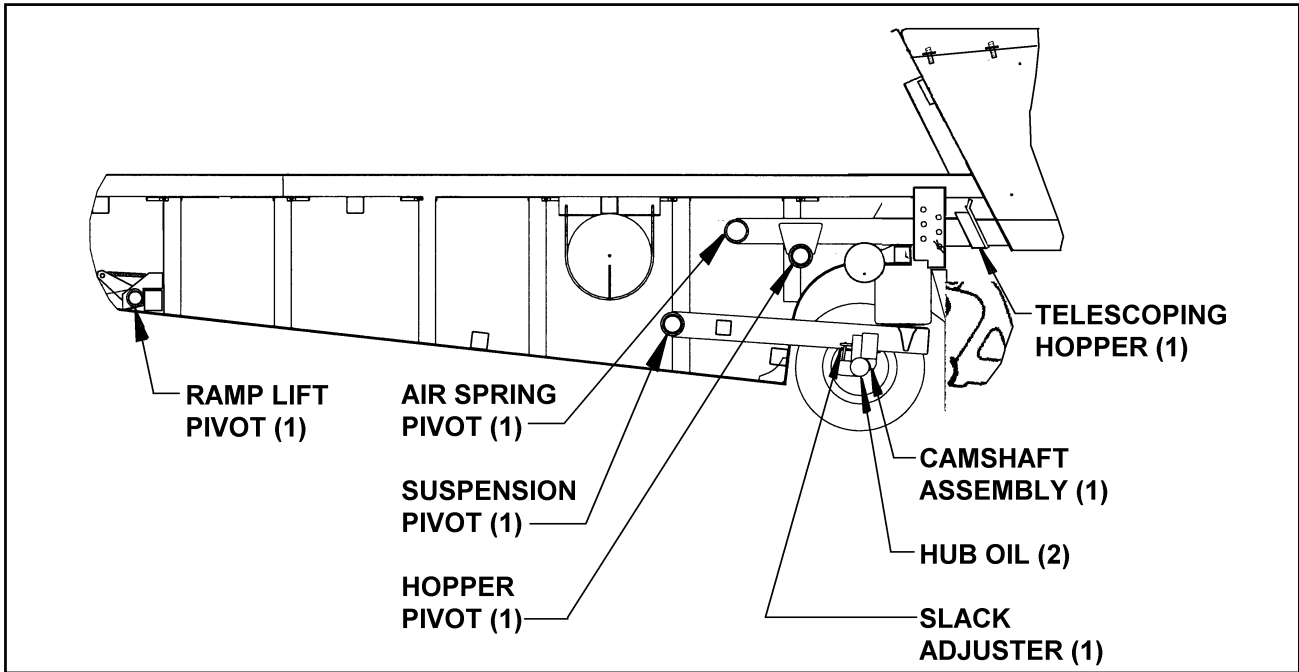

Figure 4-15 Lubrication Points

LUBE	SEASON	BRAND AND PRODUCT (WEIGHT AND/OR TYPE)			
		AMOCO	EXXON	PHILLIPS	TEXACO
1	ALL YEAR	Lit-Multi-purpose Grease	Rondex Multi-purpose Grease	Phil Lube M.W. Grease	MarFax All Purpose
2	ALL YEAR	Multi-purpose 90	Gear Oil GTX 85-140	Phil Lube All-purpose Gear SAE 90 #90501	Multi-gear EP SAE 80W-90

Table 4-1 Lubrication Specifications

NORMAL OPERATING SERVICE INTERVALS ^a								
SERVICE INTERVAL : ITEM	TIMES	Before Every Use	1st 5 Hrs	Weekly	Monthly	6 Months	Yearly	NOTES
	MILES		50	500	2,000	12,000	25,000	
LIGHTS			I	I				
WIRING & CONNECTIONS			I		I			
FASTENERS			I, T		I			b
BRAKES		O	I		C, I, L			c
BRAKE AIR SYSTEM			I	I	I			
RELAY VALVES							I, C	
BRAKE ADJ & WEAR			I		I, T			d
SLACK ADJUSTERS			I	I			L	c
CAMSHAFT ASSYS			I	I			L	c
HUB OIL			I	I, L			R	c
WHEEL BEARINGS			I			I, T		c
TIRE INFLATION & WEAR			I	I				e
WHEEL LUG NUTS			I, T	I	I, T			b
SUSPENSION					T		I, T	
SUSPENSION ALIGNMENT			I		I			
I – Inspect, R – Replace, T– Tighten/ Adjust Torque, L – Lubricate, C – Clean								
NOTES:								
a. Perform at the time shown. Shorten service intervals when operating in severe or dirty conditions.								
b. See Tables 2-2 and 2-3 for correct torque.								
c. Use lubricant per Table 4-1 .								
d. Call Landoll Customer Services or consult axle manual for procedures to replace.								
e. See Serial Number Plate on the front of the trailer for proper inflation requirements.								

Table 4-2 Maintenance Schedule

NOTES:

Troubleshooting should be performed by a trained and competent technician. Landoll Corporation is not responsible for equipment that is improperly maintained. Contact an authorized Landoll dealer or the Landoll Service department for service questions.

5-1 ELECTRICAL

Most electrical system problems show up as a burned out light or fuse, or inoperative electrical component. Wiring, grounds or components may be at fault. Locate the symptom in this section that best identifies your electrical problem. Check out each possible problem under that symptom. If the problem cannot be located, see an automotive electrical specialist. For maintenance procedures, **see Section 4-5.**

SYMPTOM	PROBLEM: REMEDY
NO LIGHTS	Fuse blown on tractor: Replace fuse. Loose connection at plug-in: Tighten connection. Broken or corroded wires: Replace wire. Ground wire loose: Clean and tighten ground.
LIGHTS FLICKERING	Wires shorted or loose: Locate, insulate, replace, or tighten.
LIGHTS DIM	Voltage difference between trailer & tractor: Tractor supply wire or circuit components too low capacity - enlarge wire or component, match bulbs with tractor voltage.
LIGHTS BRIGHT & BURN OUT	Ground wire disconnected: Self-explanatory. Voltage difference between trailer & tractor: Tractor supply wire or circuit components too low capacity - enlarge wire or component, match bulbs with tractor voltage.
FUSE BLOW-OUT OR CIRCUIT BREAKER TRIPPING	Vibration: Locate source of vibration and repair. Short circuit: Replace fuse and try all accessories. If fuse blows right away, locate short and repair.
LAMP BULB BURN OUT	Vibration: Locate source of vibration and repair. Short circuit: Replace fuse and try all accessories. If fuse blows right away, locate short and repair. Loose connection: Check lamp sockets and ground connections. Intermittent short: Locate short and repair. Improper voltage: Check voltage regulator output.

5-2 TIRES - WHEELS - SUSPENSION

Most tire, wheel, and suspension related problems are due to excessive loads, extreme conditions, and improper maintenance. Tire, wheel, and suspension problems can be easily detected and solved by checking the following guide. For maintenance procedures, see Sections 4-7 thru 4-12.

SYMPTOM	PROBLEM: REMEDY
VIBRATIONS WHILE DRIVING	Improper tire inflation: Inflate to proper pressure. Tires cupped or have flat spots: Replace tires. Wheels bent or loose: Replace or tighten. Tires incorrectly mounted: Remount. Mud in wheels: Clean wheels. Tire(s) out of balance: Balance tires. Brakes dragging: Locate cause and repair.
RAPID TIRE WEAR/DETERIORATION:	
CENTER TREAD WEAR	Over inflation: Deflate to correct inflation.
SHOULDER TREAD WEAR - BOTH SHOULDERS	Under inflation: Increase inflation to correct psi. Check axle alignment. Overload: Loads are above rated tire capacity. <i>Do not load above rated tire capacity.</i>
SHOULDER TREAD WEAR - ONE SHOULDER	Axle damage: Straighten or replace axle. Axles not parallel: Check axle alignment.
OVERALL TREAD WEAR	Overloading: Check tire load rating. High speeds: Adjust speed according to road and load conditions.
TIRE FLAT SPOTS	Quick stops: Adjust braking practices. Grabbing brakes: Adjust brakes properly. Worn or loose wheel bearings: Adjust or replace as needed. Out of balance wheels and tire: Balance wheels and tires.
UNEVEN WEAR	Suspension bushings worn: Replace bushings. Worn or loose wheel bearings: Adjust or replace as needed. Out of balance wheels and tires: Balance wheels and tires.
RIM FAILURE*:	
CRACKING	Overinflated tires: Deflate tire to proper psi. High speeds: Adjust speed according to road and load conditions. High speed cornering: Adjust cornering practices. Over loading: Check rim load rating.
*In all instances of rim failure, replace the rim immediately!	
BENDING OR WARPING	Curb-hopping or potholes: Adjust turning practices and adjust speed accordingly with road conditions. Improper tightening sequence: Follow proper tightening sequence.

SYMPTOM	PROBLEM: REMEDY
BROKEN STUDS*	Over-tightening: Use correct torque and tightening sequence when mounting.
*Replace broken studs before using the trailer!, TRAILER TRACKING PROBLEMS:	
TRACKS TO ONE SIDE	Axle bent: Replace axle.
TRACKS TO EITHER SIDE	Broken or bent axle parts: Replace axle.

5-3 BRAKES

For maintenance procedures, see Section 4-6.

SYMPTOM	PROBLEM: REMEDY
NO BRAKES OR BRAKES ARE INTERMITTENT	<p>Brake air system improperly connected: reconnect hand valves properly.</p> <p>Relay/Emergency valve plugged: clean valve.</p> <p>Defective tractor protection valve: repair or replace.</p> <p>Restricted tubing or hose line: locate and eliminate restriction.</p> <p>Broken line: locate break and repair.</p> <p>Tractor air system failure: troubleshoot tractor air system and repair. Check ABS system function.</p>
SINGLE BRAKE DRAGGING OR LOCKED	<p>Broken internal brake component: locate and replace broken part.</p> <p>Flat spot on cam roller or cam shaft: replace and lubricate.</p> <p>Improper adjustment: adjust slack adjusters.</p> <p>Spider bushing or cam bracket bushing binding: lubricate or replace bushing.</p> <p>Improper lubrication: lubricate per Figure 4-15.</p> <p>Worn brake shoe bushing: replace bushing.</p> <p>Brake drum distortion: replace drum.</p> <p>Broken brake chamber spring: replace spring.</p> <p>Brake chamber pushrod binding: re-align brake chamber bracket.</p> <p>Air brake line loose or broken: tighten or repair.</p>
UNEVEN BRAKES	<p>See "SINGLE BRAKE DRAGGING OR LOCKED"</p> <p>Restriction in hose: locate restriction and remove.</p> <p>Worn brake linings: reline brakes.</p> <p>Grease on linings: reline brakes.</p> <p>Broken slack adjuster: replace slack adjuster.</p> <p>Leaking brake chamber diaphragm: replace diaphragm.</p>

SYMPTOM

PROBLEM: REMEDY

BRAKES APPLY TOO SLOWLY

Brakes need adjusting or lubrication: adjust or lubricate as needed.
Low air pressure in brake system (below 105 PSI): check tractor air system.
Restricted tubing or hose: locate restriction and remove.
Defective relay valve: clean or replace.
Call Factory or see qualified Trailer/Brake Technician

BRAKES RELEASE TOO SLOWLY

Brakes need adjusting or lubrication: adjust or lubricate as needed.
Brake rigging binding: align brakes or replace bent parts.
Exhaust port of relay valve restricted or plugged: clean valve.
Tractor pressure too low: Adjust to provide 105 psi min.

ALL BRAKES DO NOT RELEASE

Air system improperly connected to tractor: tighten or adjust connections.
Brake valve on tractor is applied: release brake.
Relay emergency valve in emergency position: check line pressure and check valve.
Restricted tubing or line: locate restriction and remove.
Defective tractor protection valve: troubleshoot tractor air system.
Parking brakes locked: troubleshoot air system.
Moisture in air system: Check air system
Tractor pressure too low: Adjust to provide 105 psi min.

INSUFFICIENT BRAKES

Brakes need adjusting: adjust brakes.
Brakes need lubricating: lubricate brakes.
Brakes need relining: reline brakes.
Low air pressure: troubleshoot air system.
Defective relay emergency valve: repair or replace.
Brakes overheated: stop and allow brakes to cool, locate cause of overheating.

BRAKES GRABBING

Grease on brake linings: reline brakes.
Brake rigging binding: align brakes or replace bent parts.
Defective brake valve on tractor: repair or replace valve.
Defective relay emergency valve: repair or replace valve.

EXCESSIVE LEAKAGE WITH BRAKES RELEASED

Relay emergency valve leaking: repair or replace valve.
Leaking tubing or hose: replace defective part.

SYMPTOM	PROBLEM: REMEDY
EXCESSIVE LEAKAGE WITH BRAKES APPLIED	Relay emergency valve leaking: repair or replace valve. Leaking brake chamber diaphragm: replace diaphragm. Call Factory or see qualified Trailer/Brake Technician Leaking tubing or hose: replace defective part.
EXCESSIVE LEAKAGE WITH EMERGENCY SYSTEM ONLY APPLIED - NO LEAKAGE WITH NORMAL BRAKING	Defective relay emergency valve: repair or replace valve.
EXCESSIVE WATER PRESENT IN BRAKE SYSTEM	Reservoir not drained often enough: drain reservoir daily.
BRAKE WILL NOT APPLY PROPERLY	Flat spot on cam roller or camshaft: replace and lubricate.

5-4 BRAKE DRUMS

For maintenance procedures, see Section 4-6.

SYMPTOM	PROBLEM: REMEDY
EXCESSIVE LOSS OF BRAKES OR FADING	Overheated brake drums: Check for defective or misadjusted brake linings, distorted or over-machined drums. Also check for operating conditions or loads that create severe or excessive brake applications.
BRAKES PULL TO EITHER SIDE	Drums of different diameters: Replace with drums of same diameter. Foreign matter in drums: Clean drums out.
ROUGH OR NOISY BRAKING ACTION	Worn drums: Pull drums and inspect for any of the following; Heat spotted drums, grease spotting, blue drums, scored drums, excessive wear at rivet holes or edges, polished drums, out of round drums, unbalanced drums, worn/damaged brake components, foreign matter in drums. Correct situation or replace worn part(s).
VIBRATION IN RIDE	Worn or out-of-round drums: Replace drums. Out-of-balance drums: Balance drums.

5-5 RAMP LIFT AND HOPPER

SYMPTOM	PROBLEM: REMEDY
RAMP LIFT OR HOPPER FAIL TO LIFT, EXTEND, OR RETRACT, OR MOVE SLOWLY	Air system low on air: Replenish air in tank

