

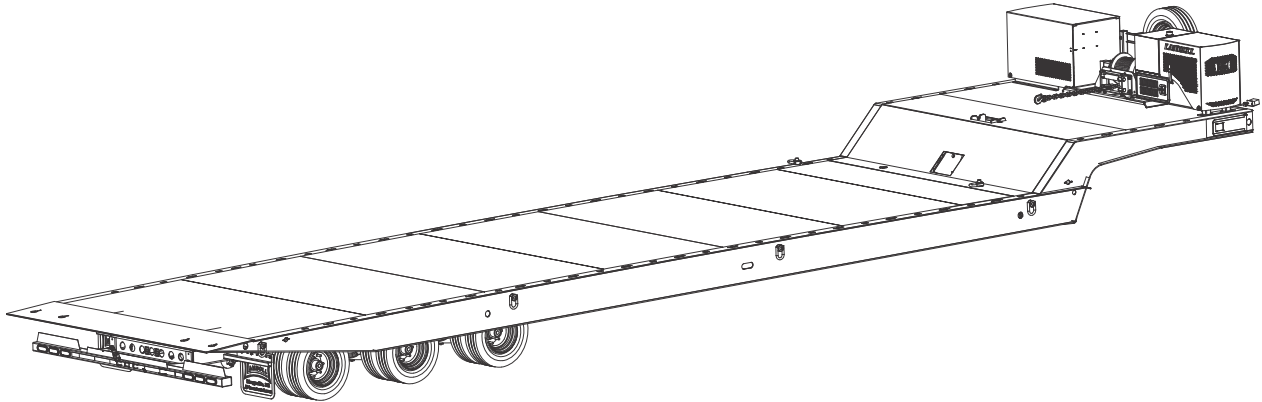

# Model 318 Lockheed Martin Supplemental Operator's Manual



**LANDOLL CORPORATION**

1900 North Street  
Marysville, Kansas 66508  
(785) 562-5381

800-428-5655 ~ [WWW.LANDOLL.COM](http://WWW.LANDOLL.COM)



# Table of Contents

---

<b>1</b>	<b>Introduction</b>	
	Understanding Safety Statements .....	1-2
<b>2</b>	<b>Operating Instructions</b>	
	Hydraulic Power Supply Diesel Engine Operation .....	2-1
	Hydraulic Power Center (Curbside) .....	2-1
	Hydraulic Power Supply Electrical Operation .....	2-3
	Replacing Hydraulic Oil Filter .....	2-3
	Strobe Light (Option) .....	2-4
	Air Height Control Valve .....	2-4
	Hand Valve .....	2-4
	Pressure Gauge .....	2-5
	Dual Winch Cable Slope Rollers .....	2-5



## Introduction

---

This manual provides supplemental operating instructions for Model 318 Lockheed semitrailer, manufactured by Landoll Corporation, Marysville, Kansas 66508.

**CHAPTER 1** Gives basic instructions on the use of this manual.

**CHAPTER 2** Gives instructions for the proper operation of the equipment.

**IF YOU HAVE ANY QUESTIONS CONTACT:**

**LANDOLL CORPORATION  
1900 NORTH STREET  
MARYSVILLE, KANSAS 66508**

**or phone:**

**(785) 562-5381 or**

**(800) 428-5655**

**or FAX:**

**(888) 527-3909**

**WARRANTY** The Warranty Registration form is included with the product documents. Fill it out and mail it within 15 days of purchase.

**NOTE: IMPROPER ASSEMBLY, MODIFICATION, OR MAINTENANCE OF YOUR LANDOLL MACHINE CAN VOID YOUR WARRANTY.**

**COMMENTS** Address comments or questions regarding this publication to:

**LANDOLL CORPORATION  
1900 NORTH STREET  
MARYSVILLE, KANSAS 66508  
ATTENTION: PUBLICATIONS -DEPT. 55**

# Understanding Safety Statements

You will find various types of safety information on the following pages and on the machine signs (decals) attached to the vehicle. This section explains their meaning.

The Safety Alert Symbol means ATTENTION! YOUR SAFETY IS INVOLVED!



### **DANGER**

**Danger means a life-threatening situation exists. Death can occur if safety measures or instructions on this label are not properly followed.**



### **WARNING**

**Warning means serious injury or death can occur if safety measures or instructions on this label are not properly followed.**



### **CAUTION**

**Caution means serious equipment or other property damage can occur if instructions on this label are not properly followed.**

#### **NOTE**

*Means that failure to follow these instructions could cause damage to the equipment or cause it to operate improperly.*

#### **NOTE**

*Make sure you read and understand the information contained in this manual and on the machine signs (decals) before you attempt to operate or maintain this vehicle.*

The safety statements contained in this manual relate to the operation of the Model 318 Lockheed semitrailer.

## Operating Instructions

### Hydraulic Power Supply Diesel Engine Operation

1. The Hydraulic Power Supply Engine system is used to power the hydraulic functions.

#### IMPORTANT

1. Check the following fluid levels before starting the engine package: engine oil, fuel supply, hydraulic oil. (Check oil level while semitrailer is not tilted as tilting will change the oil level in the tank.)
2. Flip battery shutoff switch to ON position.
3. If the engine does not crank, check the following on the battery: charge, fluid, terminals, and cables. take corrective actions as needed.



#### CAUTION

If the hydraulic fluid level is low during operation, the semitrailer may not operate correctly, resulting in damage to the semitrailer.

2. The **ENGINE IGNITION SWITCH** is located by the hydraulic controls on the driver's side of the semitrailer. Use the key to start and stop the Hydraulic Power Supply Engine (See Figure 2-1.) This switch has three positions:

OFF	In this position, the power package engine does not run. The key can only be inserted or removed from this position.
RUN	In this position, the engine runs without using the starter.
START	In this position, the starter cranks the power package engine, letting it start. After the engine is started, release the key to the RUN position.

3. The **HYDRAULIC POWER SUPPLY ENGINE THROTTLE** controls the speed at which the engine operates (See Figure 2-1.) It is a variable position control:

<b>FULL OUT</b>	In this position, the engine throttle is fully open, letting it run at full speed.
<b>FULL IN</b>	In this position, the engine throttle is closed, letting the engine run at a slow idle.

4. Warm up the engine for about five minutes before using the hydraulic controls.
5. When finished, idle for a couple minutes before turning the engine off.
6. Be sure to turn the battery switch to OFF so as to not run down the battery.

### Hydraulic Power Center (Curbside)

1. The curbside of the upper deck trailer allows access to the hydraulic tank, fuel tank, diesel engine, and batteries (See Figure 2-2.)

# OPERATING INSTRUCTIONS

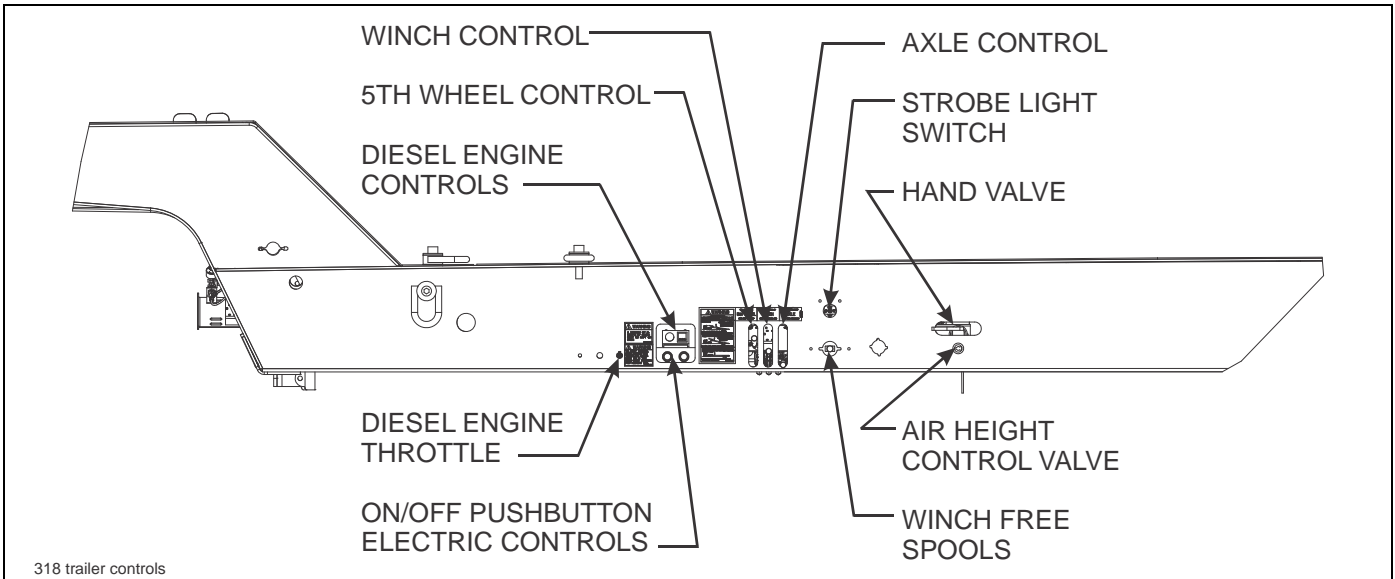

**Figure 2-1: Streetside Trailer Controls**

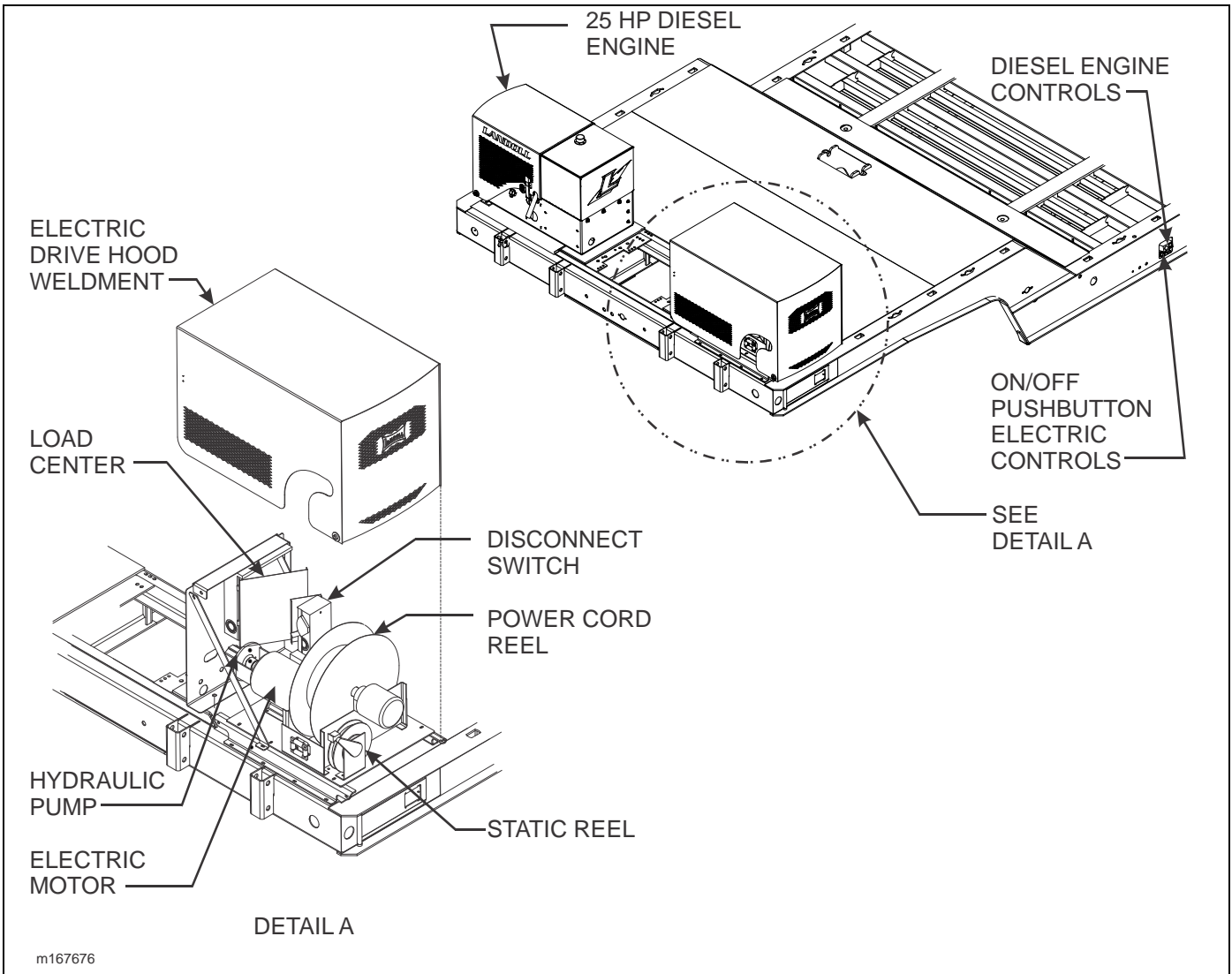

**Figure 2-2: Diesel and Electrical Power Center**



## Hydraulic Power Supply Electrical Operation

1. The Hydraulic Power Supply Electrical system located on the streetside of the trailer is also used to power the hydraulic system.

### IMPORTANT

1. **Check the hydraulic oil level before starting the hydraulic power supply electrical package. (Check oil level while semitrailer is not tilted as tilting will change the oil level in the tank.)**



### CAUTION

**If the hydraulic fluid level is low during operation, the semitrailer may not operate correctly, resulting in damage to the semitrailer.**

2. The electrical power cord reel is located on the streetside of the trailer (**See Figure 2-2.**) Extend cord and connect to an appropriate 208-220 volt building power receptacle.
3. To start the electric motor for the hydraulic pump, press the start button on the streetside of the trailer (**See Figure 2-2.**)
4. Operate all hydraulic functions and controls the same as for the diesel engine operation.
5. When finished, stop the electric motor with the stop button located on the streetside of the trailer (**See Figure 2-2.**)
6. Disconnect the power cord from the building receptacle, and retract the cord onto the power cord reel.

## Replacing Hydraulic Oil Filter

1. Shutdown both electrical and diesel power units, to ensure that hydraulic systems are not in use. Remove key and turn off main electrical breaker to prevent inadvertent use of the hydraulic systems during the filter change.
2. Loosen clamp that is securing the return line shutoff valve handle to the side of the return line shutoff valve. Install handle onto shutoff valve toward return line filter (**See Figure 2-3.**)
3. Turn valve handle 90 degrees to isolate the hydraulic oil in the tank from the return line filter. This will keep the hydraulic oil in the tank from draining out during the filter change.
4. Thoroughly clean return line filter area, and remove existing filter. Once removed clean filter head using a lint free cloth.
5. Lubricate rubber filter seal with hydraulic oil on the replacement filter, and reinstall it on the return line filter head.
6. Once filter has been reinstalled and tighten, open return line shutoff valve by turning the handle back to its open position (**See Figure 2-3.**)
7. Remove handle from the shutoff valve, and secure back to the side of the return line shutoff valve using clamp.
8. Check hydraulic oil level.
9. Once complete the electrical and diesel power units should be ready for operation.



### CAUTION

**Failure to open the shutoff valve after it has been closed for maintenance can result in a rupture of the hydraulic filter or other damage to the hydraulic system.**

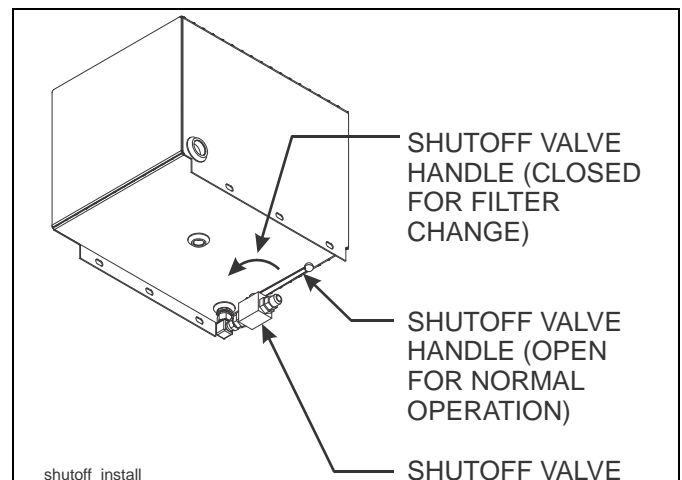

**Figure 2-3: Shutoff Valve and Handle**

## Strobe Light (Option)

The **STROBE LIGHT SWITCH** is on the hydraulic control panel (See Figure 2-1.) The strobe light switch is used to turn on strobe warning lights at the rear.

## Air Height Control Valve

The **AIR HEIGHT CONTROL VALVE** (See Figures 2-1 and 2-4) is located on the streetside of the trailer, just behind the main hydraulic control valve. It has two positions:

<b>ON</b>	Placing the valve in this position allows manual adjustment of the air ride height.
<b>OFF</b>	Placing the valve in this position returns the air ride height adjustment to the automatic mode.

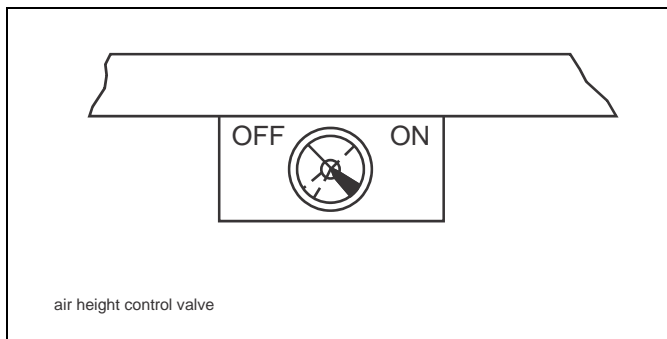

Figure 2-4: Air Height Control Valve

## Hand Valve

The **HAND VALVE** (See Figures 2-1 and 2-5) is located on the streetside of the trailer, just behind the main hydraulic control valve. It has two positions:

<b>RIGHT</b>	Placing the valve in this position will exhaust the air from the air ride system, lowering the trailer deck when the <b>AIR HEIGHT CONTROL VALVE</b> is in the "ON" position.
<b>LEFT</b>	Placing the valve in this position will increase the air pressure in the air ride system, raising the trailer deck when the <b>AIR HEIGHT CONTROL VALVE</b> is in the "ON" position.

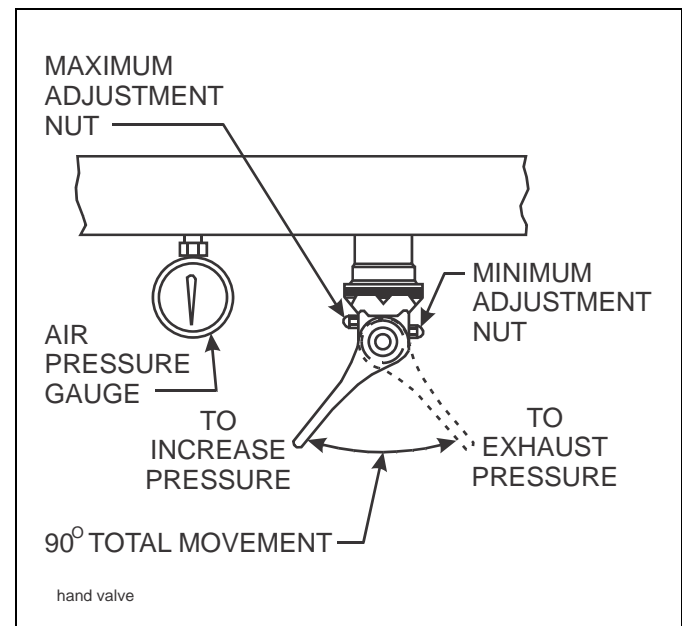

Figure 2-5: Hand Valve

## Pressure Gauge

The **PRESSURE GAUGE** (See **Figure 2-5.**) is located near the **HAND VALVE**. This gauge provides air pressure information for adjusting the air ride system manually.

1. Minimum air pressure should be at least three (3) psi. Loosen the minimum adjustment nut (See **Figure 2-5.**), set the air pressure at three (3) psi and tighten the nut again.
2. Maximum air pressure should be no more than 85 psi. Loosen the maximum adjusting nut (See **Figure 2-5.**), set the air pressure at 85 psi and tighten the nut again.

### IMPORTANT

The **Trailer Lift Lever** (See **Figure 2-1.**) and the **Hand Valve** (See “**Hand Valve**” on page 2-4.) may be utilized to raise or lower their respective end of the semitrailer to clear obstacles during transport (i.e. low bridges, curbs, etc.) by following the directions for use of controls.

## Dual Winch Cable Slope Rollers

The trailer is equipped with **Dual Slope Rollers** to allow the winch cable to pull the load with the cable parallel with the lower deck (See **Figure 2-6.**)

1. When connecting the winch cable to a load that has the connection point over 25” above the ground, the winch cable does not need to go through the slope rollers. The winch cable will last longer if going through the slope rollers can be avoided.

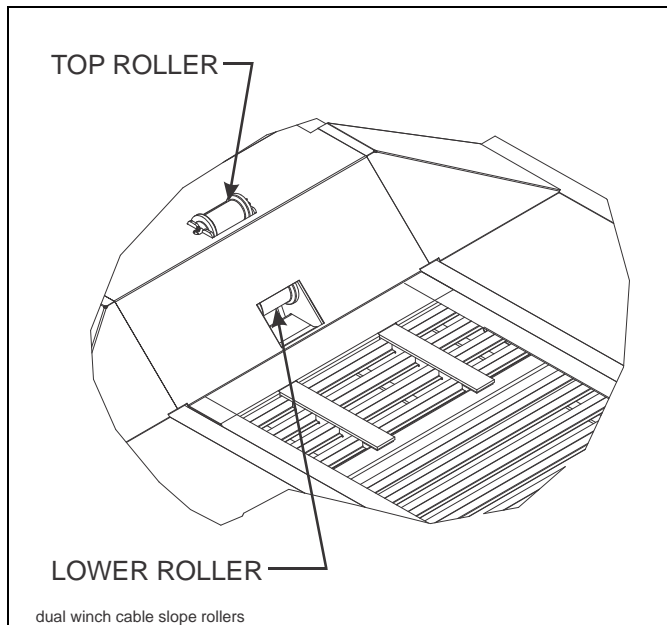

**Figure 2-6: Dual Winch Cable Slope Rollers**







Equipment from Landoll Corporation is built to exacting standards ensured by ISO 9001:2008 registration at all Landoll manufacturing facilities.

Model 318  
Lockheed Martin Supplemental  
Operator's Manual

Re-Order Part Number F-634-0112

**LANDOLL CORPORATION**

1900 North Street  
Marysville, Kansas 66508  
(785) 562-5381  
**800-428-5655 ~ WWW.LANDOLL.COM**



Copyright 2010. Landoll Corporation

"All rights reserved, including the right to reproduce this material or portions thereof in any form"